



iMaser™ 3000

ACTIVE HYDROGEN MASER

Installation, Operation & Maintenance User Manual





Document Editor Log

	Name	Date	Signature
Prepared by	S. Froidevaux	28.05.10	

Document Change Log

Issue	Date	Chapter
1.0	21.Aug.2006	All
1.1	09.07.2007	
1.2	20.07.2007	6.3
	10.04.2008	14
1.4	24.08.08	EMC option
1.5	22.09.09	Imaser 3000, Alarm condition, 10MHz option, Out-of-Lock
1.6	27.01.10	Alarm action (option)
1.7	28.05.10	Logo / monitoring



Table of Contents

1. REFERENCE DOCUMENTS.....	5
2. LIST OF ACRONYMS	5
3. INTRODUCTION	6
4. MASER PRINCIPLE	7
5. MASER FUNCTIONAL DESCRIPTION	9
5.1. MASER DESCRIPTION	9
5.2. PHYSICS PACKAGE	10
5.2.1. Hydrogen Atomic Beam & Storage Bulb	11
5.2.2. Microwave Cavity & Atomic Signal.....	11
5.2.3. Vacuum Systems	12
5.3. ELECTRONICS PACKAGE	12
5.3.1. Receiver & PLL	13
5.3.2. 1 PPS Clock	15
5.3.3. Heater Controllers (Physics Package).....	15
5.3.4. Hydrogen Distribution Controller	17
5.3.5. HF Oscillator for the Dissociator with the Light Detector	17
5.3.6. High Voltage Supplies for the Ion Pumps	17
5.3.7. Power Distribution	18
5.4. ELECTRICAL INTERFACES.....	18
5.4.1. Front Panel View & Control.....	18
5.4.2. Power Connection.....	20
5.4.3. Power Switches.....	21
5.4.4. Sine outputs & 1 Pulse per Second Output.....	21
5.4.5. Parameter Connectors.....	22
5.4.6. Physical Parameter Adjustments	23
5.4.7. Control LEDs.....	24
5.4.8. Out of lock relay	24
5.5. MONITORING & CONTROL CONCEPT	25
5.5.1. Parameter Monitoring.....	25
5.5.2. Main Frequency Synthesiser.....	26
5.5.3. Data Transfer Protocol.....	27
6. MASER SPECIFICATIONS	29
6.1. ELECTRICAL INTERFACES.....	29
6.1.1. Sine Outputs	29
6.1.2. 1 Pulse per Second Output	30
6.1.3. Power Consumption.....	31
6.2. MECHANICAL CHARACTERISTICS	31
6.3. UPS (OPTIONAL).....	32
6.3.1. Battery Type.....	32
6.3.2. Battery Sets.....	32
6.3.3. Battery Charger.....	33
6.3.4. Powering in Nominal Operation	33
6.3.5. DC Power Supplies in Parallel	34
6.3.6. Verification of the UPS Batteries.....	34
6.3.7. Spare Batteries & Replacement.....	35
7. POWERING THE MASER	36



8.	STARTING PROCEDURE (STANDBY TO OPERATING MODE)	36
9.	SWITCH-OFF PROCEDURE (OPERATING TO STANDBY MODE)	38
10.	TRANSPORTATION UNDER POWER CONDITIONS	38
10.1.	OPERATING TO STANDBY MODE.....	38
10.2.	LOGBOOK & HANDLING	39
10.3.	INSTALLATION IN THE TRANSPORT BOX.....	39
10.4.	MASER INSTALLATION.....	40
11.	OPERATING & CALIBRATION CHECK	41
11.1.	ADJUSTMENT OF THE FREQUENCY SYNTHESIZER.....	41
11.2.	ADJUSTMENT OF THE 1 PPS CLOCK.....	42
11.2.1.	<i>Digital Clock</i>	42
11.2.2.	<i>1 Hz Pulse</i>	43
11.3.	ADJUSTMENT OF THE MOLECULAR HYDROGEN FLUX.....	43
11.4.	ADJUSTMENT OF THE DISCHARGE HF OSCILLATOR.....	44
11.5.	EVALUATION OF THE MASER QUALITY FACTOR	44
11.6.	EVALUATION OF THE SPIN EXCHANGE TUNING	45
12.	NOMINAL RANGES & ALARMS CONDITION	46
13.	ANNEXES	47
13.1.	MASER FREQUENCY DEFINITIONS	47
13.1.1.	<i>Unperturbed Hydrogen Atom Frequency</i>	47
13.1.2.	<i>Influence of Magnetic Field on Atom Frequency</i>	47
13.1.3.	<i>Zeeman Frequency</i>	48
13.1.4.	<i>Hydrogen Atom Frequency in the Maser</i>	48
13.1.5.	<i>Cavity Frequency & Output Maser Frequency</i>	48
13.1.6.	<i>User Output Frequencies (Chapter 5.4.4)</i>	49
13.2.	FREQUENCY STABILITY	49
13.2.1.	<i>Definitions of the Allan Variance</i>	49
13.2.2.	<i>Definition of the Noise Processes</i>	51
13.3.	FREQUENCY OFFSET, FREQUENCY DRIFT & TIME ERROR	53
14.	CE CERTIFICATIONS (MARCH 2008)	53



1. Reference Documents

- Ref. 1:** Kleppner D, Goldenberg H M, Ramsey N F: Theory of the Hydrogen Maser, Physical Review 126, No 2 (1962)
- Ref. 2:** Kleppner D et al: Hydrogen-Maser Principles and Techniques, Physical Review 138, No 4A (1965)
- Ref. 3:** Vanier J, Audoin C: The Quantum Physics of Atomic Frequency Standards (2 Volumes), Adam Hilger, Bristol and Philadelphia, 1989
- Ref. 4:** Audoin C, Guinot B: Les Fondements de la Mesure du Temps, Masson, Paris, 1998
- Ref. 5:** Handbook on Selection and Use of Precise Frequency and Time Systems, Radiocommunication Bureau, International Telecommunication Union, Geneva, 1997

2. List of Acronyms

DDS	Direct Digital Synthesiser
ENBW	Equivalent Noise Bandwidth
MASER	Microwave Amplification by Stimulated Emission of Radiation
Maser	Hydrogen MASER or iMaser 3000 Product
OEXO	Oven Controlled Oscillator (Ultra Stable Oscillator)
ON	Neuchâtel Observatory
PLL	Phase Lock Loop
PPS	One Pulse Per Second clock
RH	Relative Humidity
T4S	T4Science
UPS	Uninterruptible Power Supply



3. Introduction

Through the acquisition of the Maser Technology Group of the ON in 2006, T4Science (T4S) has over 25 years experience in producing high-performance Masers for its fast-growing customer base. T4S' technology has evolved into 4 types of Maser generation: first generation with the EFOS_A; second generation with the EFOS_B; third generation with the EFOS_C; and fourth generation with the iMaser 3000.

This user manual provides information for the start-up and operation of the instrument, including the installation and servicing of the Maser.

Operating and calibration checks are included, in particular the evaluation of the atomic Quality factor of the instrument.

General description of the Maser principle is included. The electronics block diagrams are illustrated but the detailed diagrams are delivered as separated folder for each Maser serial number. (see the test report)

This manual doesn't include the monitoring program description which is given separately.

Some module referenced in this manual may not be present in several version. They must be ordered as options.

SAFETY



Use proper ESD precaution

Ensure that all cables are properly connected

Signal Cable length should be shorter than 30 meters!

Don't open box without training: Risk of Hazards

4. Maser Principle

MASER stands for Microwave Amplification by Stimulated Emission of Radiation.

The Hydrogen Maser is an active oscillator with a natural output derived from the quantum transition between two of the hyperfine levels ($F=1, m_F=0$ to $F=0, m_F=0$) of the ground electronic state of atomic hydrogen (Figure 1). This corresponds to the well known 21 cm line or $\nu_{HFS} = 1420'405'751.770 \pm 0.003 \text{ Hz}$.

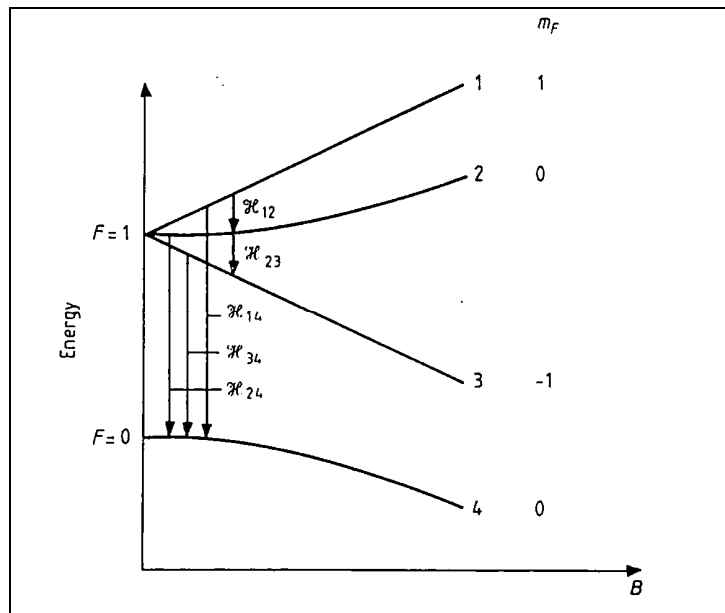

Figure 1 : Hydrogen atom ground state hyperfine structure

The Hydrogen Maser operates as follows (Figure 2):

Molecular Hydrogen, supplied from a storage bottle, is dissociated into atoms by an HF plasma discharge in the H source.

Leaving the H source, the atoms enter a State Selector which directs the beam of atoms in the appropriate quantum state ($F=1, m_F=0$ and $F=1, m_F=1$) into a quartz Storage bulb coated with Teflon to minimise the interactions of Hydrogen atoms with the bulb walls.

The storage bulb is placed in the centre of a Microwave cavity using the TE011 mode. The cavity is tuned close to the hyperfine structure transition of the Hydrogen atom. The tuning of the cavity is controlled by the cavity temperature (coarse adjustment) and by a Varactor diode.

If the atomic flux is high enough, about 10^{12} atoms/s, the energy available from the stimulated emission of radiation is sufficient to overcome the microwave losses of the

cavity and a sustained atomic oscillation is obtained and produces an output signal larger than 10^{-14} Watt with a line width of typically 1 Hz at 1.420 GHz.

The vacuum in the Storage bulb, required for the functioning of the Maser, is maintained with getters and ion pumps.

The cavity itself is surrounded by a Solenoid to create a homogeneous and defined magnetic field (C-field). A Magnetic shield ensemble minimises the influence of the ambient magnetic field.

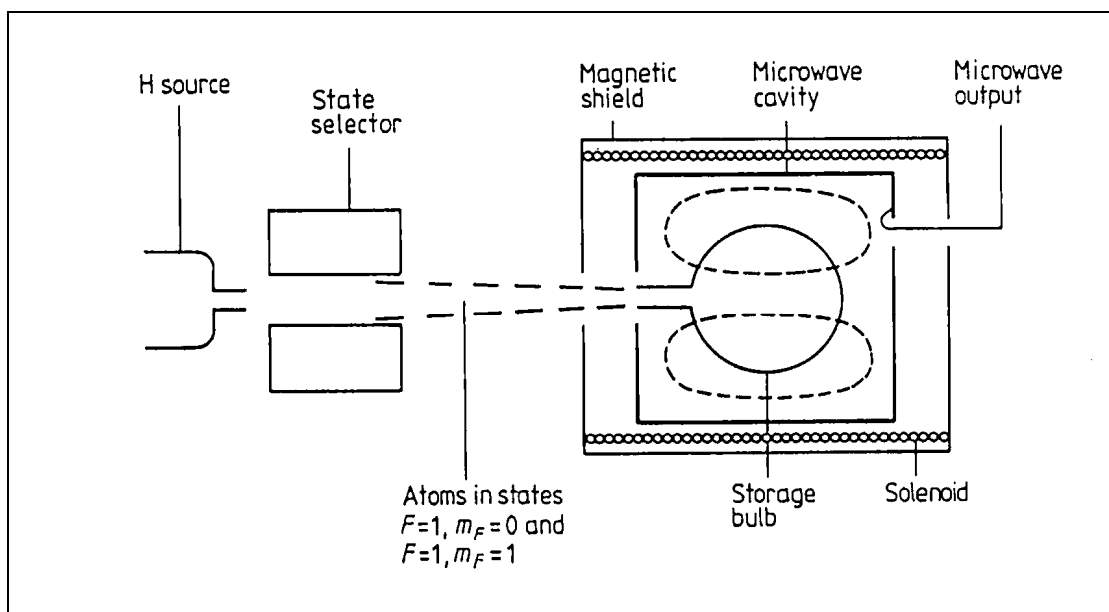

Figure 2 : Hydrogen Maser principle

Thermal controls of the microwave cavity, essential for achieving excellent frequency stability of the instrument, is obtained with heaters and a vacuum thermal isolation.

A coupling loop, mounted in the cavity, extracts part of the Maser energy to the low noise receiver and the Phase Lock Loop (PLL) which includes the local quartz oscillator (OCXO).

The PLL bandwidth is adjusted (1 Hz) to take advantage of:

- the low phase noise of the OCXO (above 1 Hz),
- the stability of the Maser (above 1 second).

The main PLL bandwidth have been set slower to 2-3s for LN option and 1 s as standard.



5. Maser Functional Description

5.1. Maser Description

The Maser consists of two distinct parts integrated in a rack: the Physics Package and the Electronics Package.

The rack is customised dimension due to the non-standard dimensions of the Physics Package.

The Physics Package is the heart of the Maser. It contains the Hydrogen distribution system (Hydrogen Supply and Atomic source) the Hydrogen Storage bulb, the Microwave cavity and Magnetic shield assembly, the Vacuum systems.

The Electronics Package includes the critical electronics (low noise and main PLL with the OCXO) and the secondary electronics (power supply, Hydrogen distribution controller, heater controller,...)

5.2. Physics Package

The schematic drawing of the Physics Package is shown on Figure 3

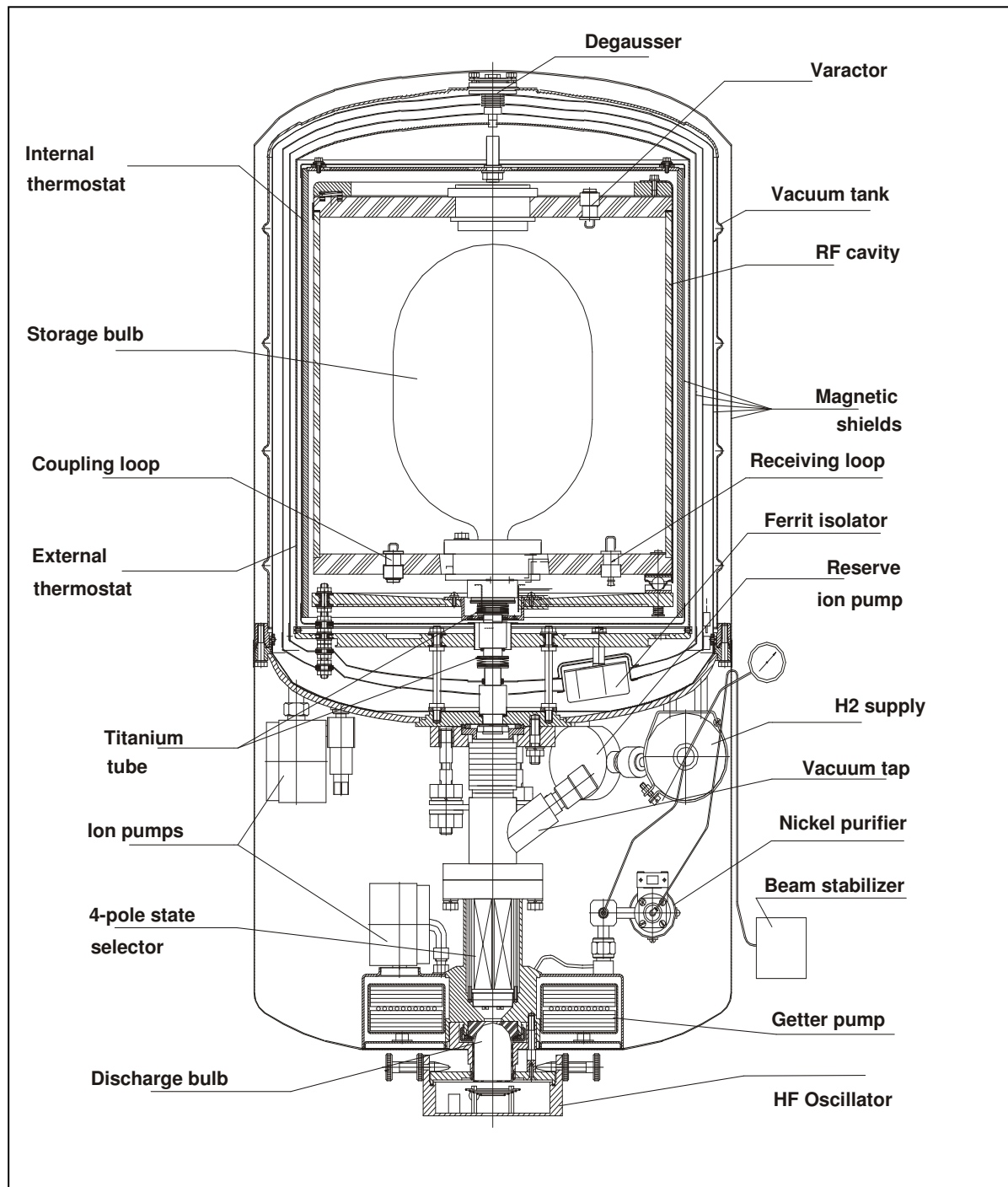

Figure 3 : Physics Package



5.2.1. Hydrogen Atomic Beam & Storage Bulb

The Hydrogen is supplied from a heated solid state metallic storage compound (LaNi_5H_x), which releases the gas as function of temperature.

The molecular Hydrogen flux is purified and controlled by the “beam stabiliser” system which regulates a Nickel valve by heating. The Nickel valve is based on Hydrogen permeation through the metal depending on temperature. Its temperature is adjusted to produced a stable Hydrogen pressure in the Dissociator. The Hydrogen pressure in the Dissociator is measured with a Pirani sensor.

Hydrogen is produced in the Dissociator (quartz discharge bulb) by a plasma discharge. The discharge is excited by an oscillator coupled to a flat coil.

Leaving the discharge bulb through a collimator, the beam of atoms intersects a 4-pole magnetic state selector which focuses atoms in the upper $F=1$, $m_F=0$ and $m_F=1$ hyperfine levels into the quartz storage bulb, while the others are defocused off-line and pumped off.

The valve (vacuum tap) in the Hydrogen tube is maintained open in normal operation. It can be closed for maintenance to protect the quartz storage bulb (Teflon coating) from atmosphere in case of intervention on the Hydrogen distribution for service.

5.2.2. Microwave Cavity & Atomic Signal

The storage bulb is placed in the centre of the Microwave cavity (TE011) consisting of a glass ceramic system silver coated and temperature stabilised.

Two RF loops are connected to the cavity: a coupling loop used for test and calibration purposes and the receiving loop which extracts part of the atomic signal towards the low noise receiver through an RF ferrite isolator.

The resonance frequency of the microwave cavity can be finely adjusted by means of a Varactor.

The system is magnetically screened by 4 concentric shielding having a total shielding factor of typically 10^5 .

The temperature of the cavity is stabilised with a two-stage oven (internal and external thermostats) of 7 heaters.

5.2.3. Vacuum Systems

Two independent systems must be distinguished: the Hydrogen vacuum and the Thermal vacuum.

The Hydrogen system, also named “internal”, maintains the vacuum in the Hydrogen storage bulb. The pumping is assured by a getter assembly and an ion pump powered at several kilovolts.

The Thermal system, also named “external”, maintains the vacuum in the cavity volume for thermal insulation of the heaters. The pumping is assured by an ion pump powered at several kilovolts.

5.3. Electronics Package

The Electronics Package consists of:

- the low noise receiver/PLL and the ultra-stable oscillator (OCXO)
- the monitoring
- the 1 PPS clock
- the heater controllers (Internal and External thermostats of the Physics Package)
- the Hydrogen distribution controller
- the HF oscillator for the Dissociator with the light detector
- the high voltage supplies for the ion pumps
- the power distribution

The general block diagram of the Electronics Package is shown on next figure.

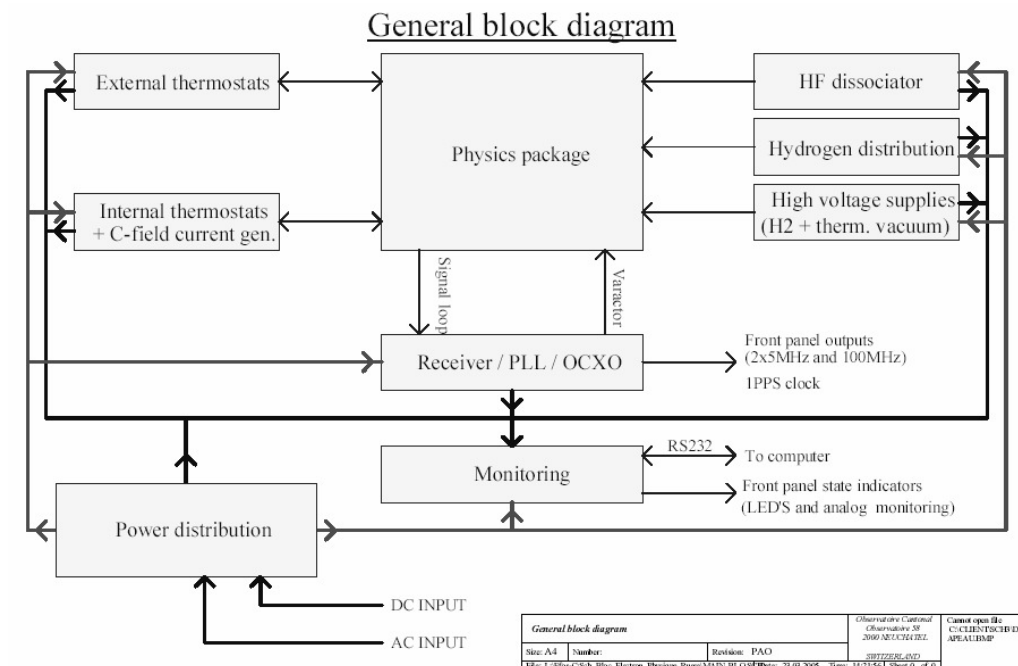

Figure 4: General block diagram of the Electronics Package

5.3.1. Receiver & PLL

5.3.1.1. Receiver and PLL description

The low noise receiver is the most critical electronics of the Maser because it must amplify the very low Maser signal (typically 10^{-13} Watt). Its schematic drawing is shown on Figure 5.

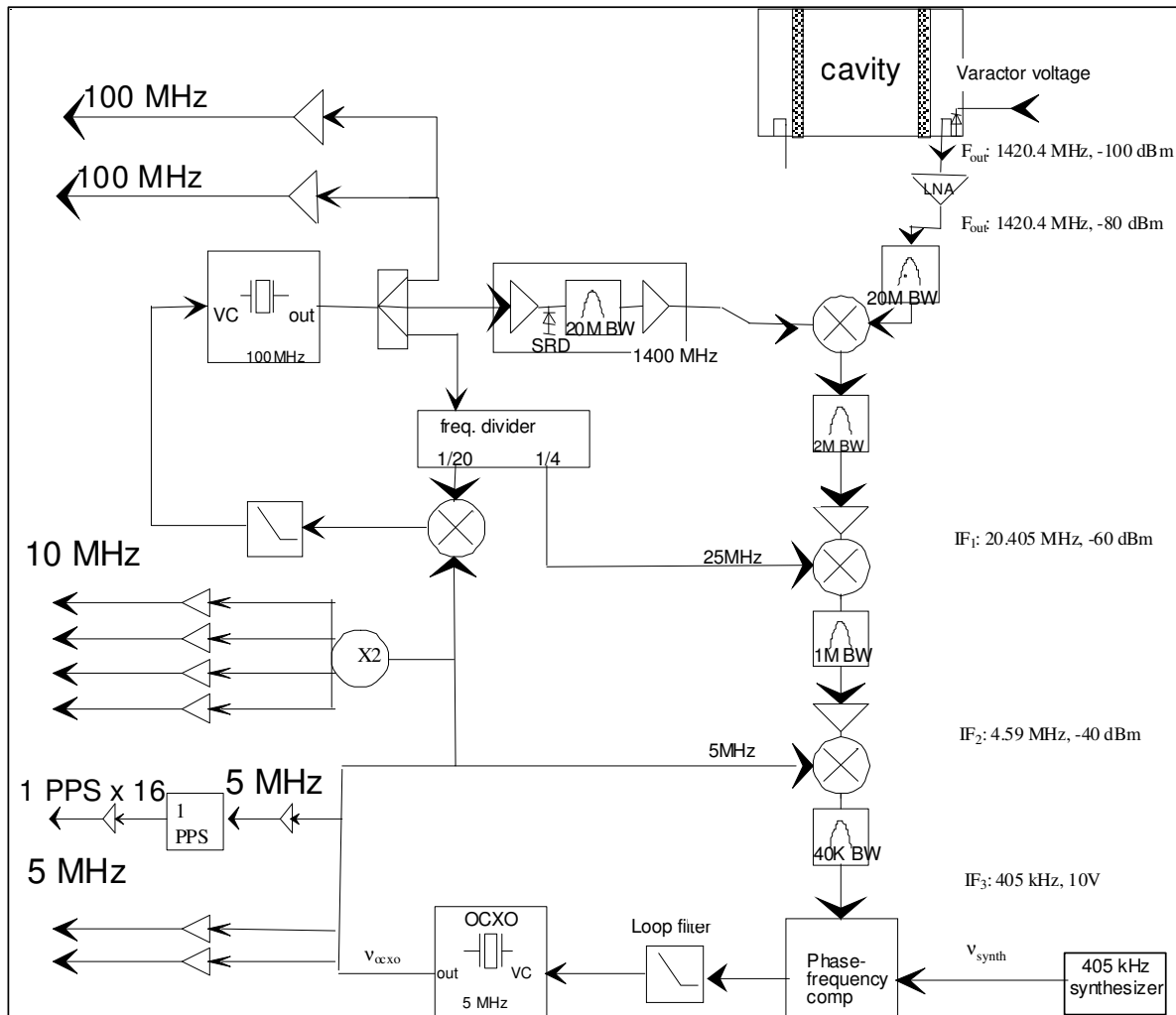

Figure 5 : Low Noise Receiver & PLL

The atomic signal extracted from the cavity by the receiving loop is first amplified by 20 dB (LNA) then down-converted from 1'420.405... MHz to 405... kHz in three steps, using mixers and intermediate frequencies derived from the local oscillator: 1'400 MHz, 25 MHz and 5 MHz.

At 405... kHz, the atomic signal is phase compared (PLL) to the synthesiser output. The PLL output is finally sent to the local oscillator (OCXO) as a correction signal.



The synthesiser is based on a 32 bit DDS at 1.936 MHz generated by the 5 MHz derived from the OCXO. The 1.936 MHz signal follows different steps: divisions by 7 bits, mixing and filtering with quartz. The final synthesiser signal at 405'751Hz has a resolution of $32+7=39$ bit derived from the 5 MHz corresponding to a final resolution of $9.09 \cdot 10^{-6}$ Hz. This corresponds to a frequency resolution of $6.4 \cdot 10^{-15}$ relative to the Maser frequency.

In addition to the main 5 MHz outputs, the intermediate frequency of 100 MHz, necessary for the production of the 1'400 MHz of the down-conversion, is made available as standard output.

5.3.1.2. Receiver and PLL units and boards (including monitoring)

The Receiver and PLL are separated in 3 physical **units** thermally controlled and the OCXO. The 3 **units** are mounted on a thermally conductive plate (aluminium) in a thermally insulated box. The thermal controller is part of the UP/DOWN converter board.

- The **OCXO** is mounted in the Maser racks, closed to the **Receiver/PLL units**.
- The **5 MHz distribution / 100 MHz PLL unit** contains the **5 MHz distribution board** and the **100 MHz PLL board**.

The 5 MHz output of the Ultra-Stable Oscillator Varactor (OCXO) feeds the 5 MHz distribution board which delivers 2 sinus outputs to the Front Panel of the Maser and one for locking the 1 PPS clock. Internal 5 MHz outputs are used for the down conversion, the 405 kHz synthesiser and the 100 MHz PLL.

The 10 MHz output is derived from the 5MHz by a direct double stage.

The 100 MHz PLL is locked on the 5 MHz and delivers 1 sinus output to the Front Panel of the Maser. Internal 100 MHz outputs are used for the multiplication to 1400 MHz and for the down conversion.

- The **UP/DOWN converter unit** contains the **UP/DOWN converter board** and the low noise amplifier (**LNA**) for the atomic signal.

The first intermediate frequency at 1400 MHz is derived from the 100 MHz (step recovery diode SRD). The second intermediate frequency at 25 MHz is derived from the 100 MHz by division. The third intermediate frequency at 5 MHz comes from the 5 MHz distribution board.

The main output of the **UP/DOWN converter** is the atomic signal amplified and shifted from 1420.405751 MHz to 405.751 kHz. This 405.751 kHz signal is fed to the **PLL board**.

The thermal controller of the Receiver and PLL is integrated on the UP/DOWN converter board.

- the **PLL unit** contains the **PLL board** and the **Monitoring board**.

The 405.751 kHz signal coming out from the **UP/DOWN converter** is phase compared to the 405 kHz synthesised signal produced on the **PLL board** by a 32 bit Direct Digital Synthesiser (DDS).

The main output of the **PLL board** is the correction signal for the OCXO. The **PLL board** delivers also the stable voltage of the Varactor diode adjusting the cavity resonance frequency (Chapter 3).

A Microprocessor is integrated on the **PLL board** to control the DDS frequency synthesiser and the Monitoring acquisition.

The **Monitoring board** of 40 channels (32 with 12 bits resolution and 8 with 8 bits resolution) allows for acquisition of Maser parameters: status of the Receiver/PLL/OCXO, atomic amplitude, Hydrogen distribution, power supply, heaters, ...

5.3.2. 1 PPS Clock

A 1 PPS (pulse per second) clock is locked on a 5 MHz output of the 5 MHz distribution unit. It consists of two distinct parts:

- digital clock (month, year, day of week, hour, minute, second)
- 1 Hz pulse generator with a 50 ns adjustment resolution
- 16 output pulse distributor

5.3.3. Heater Controllers (Physics Package)

Two **Heater Controllers** are used for the Physics Package. The External Thermostat comprises four heaters (ES, EB, T, I) and the Internal thermostat comprises three heaters (IT, IS, IB) and the C-field current generator.

The block diagrams of the Heater controllers are shown on **Figure 6** and **Figure 7**.

External thermostat block diagram

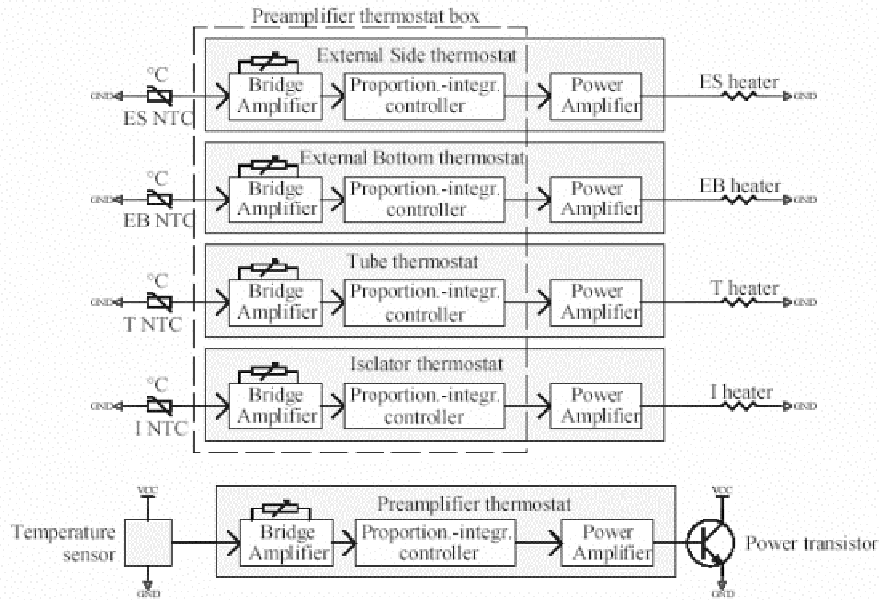

Figure 6: External Thermostat Controller

Internal thermostat block diagram

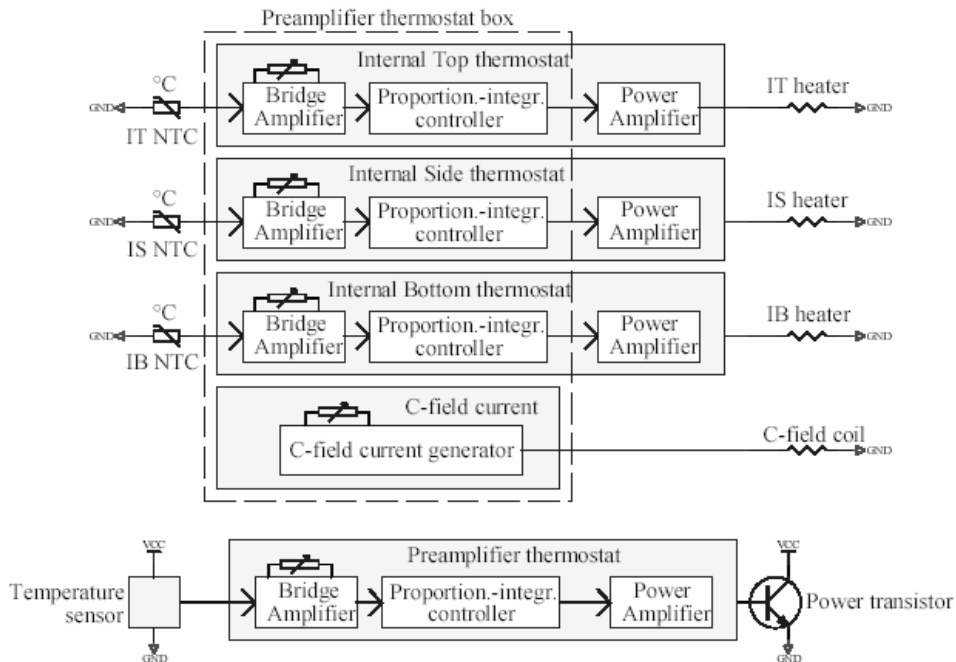

Figure 7: Internal Thermostat Controller

5.3.4. Hydrogen Distribution Controller

The **Hydrogen distribution controller**, or **Beam stabiliser**, controls the Hydrogen storage temperature (LaNi₅H)_x, the Pirani heater measuring the pressure in the Dissociator and the current heating the Nickel valve.

The block diagrams of the Beam stabiliser is shown on **Figure 8**.

Beam stabilizer block diagram

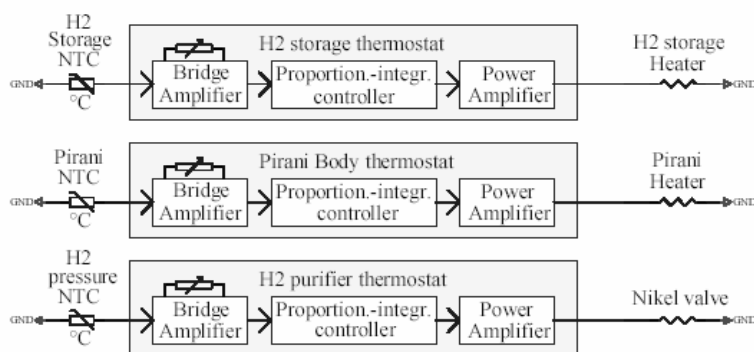

Figure 8: Beam stabiliser controller

5.3.5. HF Oscillator for the Dissociator with the Light Detector

The **HF oscillator** coupled to a flat coil excites the plasma in the Dissociator to produce the atoms. A light detector is mounted close to the Dissociator to monitor the light emitted when the discharge is operating.

5.3.6. High Voltage Supplies for the Ion Pumps

Two High Voltage supplies are used for respectively the Hydrogen vacuum and the Thermal vacuum.

- Manufacturer: HighTek Power
- Type: PSM10
- Model: 502p (+50V to +5kV, 2 mA)

5.3.7. Power Distribution

The **Power Distribution unit** consists of one AC to DC converter, two DC/DC converters and a **Power Distribution board**.

The types of AC/DC and DC/DC converters are: Manufacturer: Polyamp Models:

- PSE100AC24, for the AC/DC converter (230V to 24V)
- PSE100B24, for the DC/DC converter (24V to 24V)
- PSC80AR15 S5-15, for the DC/DC converter (24V to $\pm 15V$, +5V)

5.4. Electrical Interfaces

5.4.1. Front Panel View & Control

For EMC reason the front door shall be closed while in normal operation

The information LED are replicated on the main door in order to give the status of the MASER



Figure 9: Front Door view

The control of the switch are accessible when the door is open. (Please DO NOT OPEN if not necessary).

The general view of the Front Panel (Figure 10) shows the main interface:

The 3 panel on the top have the following function

- the LED and switch controls
- The 1PPS pulse and digital clock generator
- the varactor and hydrogen control and the temperature probe and the telemetry serial interface

The other module are:

- The internal oscillator
- The thermostated control electronic package
- The main power distribution board

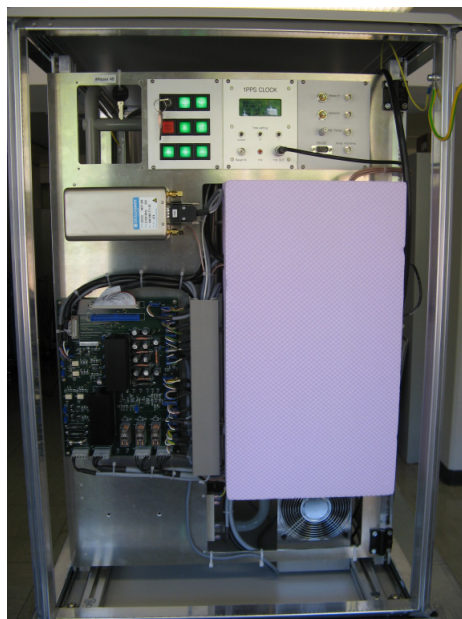

Figure 10: Front Panel General View

5.4.2. Power Connection

The Maser can be powered with one DC supply and an AC supply.

The two DC supplies (22 to 30 VDC), protected and isolated with diodes, allow for power redundancy or for switching from a power supply to another without interruption.

The two DC cables are connected to the Main power distribution board on the front panel see **Figure 9** and the cables pass through the EMC tolerant opening on the rear side of the Maser see **Figure 11**

The AC voltage allows for powering with the main line (230 V, 50 Hz) through a connector of type IEC 320 located on the rear panel of the Maser.



Figure 11: AC Power Connector & Cables Entry Point

A LED is lighting when the Maser is powered by one or both DC connectors. A LED is lighting when the Maser is powered by the AC connector (**Figure 12**). The light intensity depends on the voltage level.

The connector for AC voltage (**Figure 11**). The AC supply is monitored as channel "B".

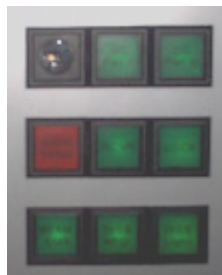

Figure 12: Main Power Monitoring & Switches



5.4.3. Power Switches

A switch ensemble, located on the Front Panel (**Figure 12**), allows to switch on and off sub-assemblies of the Instrument. It comprises 4 press-buttons and one key and 4 monitoring LED.

- The “key-switch” is the general switch: it enables the powering of all sub-assemblies, including the thermal controls and the vacuum ion pumps. It is therefore highly recommended to avoid any interruption (chapter 7).
- The “HF rcvr” switch enables the powering of the main Electronics (monitoring board, low noise receiver, OCXO and 1 PPS clock).
- The “Beam stab” switch enables the powering of the Hydrogen distribution (beam stabilizer and molecular Hydrogen storage).
- The “RF osc” switch enables the powering of the RF oscillator/HF generator

5.4.4. Sine outputs & 1 Pulse per Second Output

According the option chosen the following output frequency are available via a Ntype connector:

- 2x 5MHz output frequency
- 2x 100MHz output frequency
- 4x 10MHz output frequency (options)

A “one pulse per second” (1 PPS) distribution unit provide from to 16* 1PPS output, according the option chosen, via a “BNC” type connectors.

The Connection is located on the rear panel and the cable shall pass through the EMC tolerant opening on the rear side of the Maser

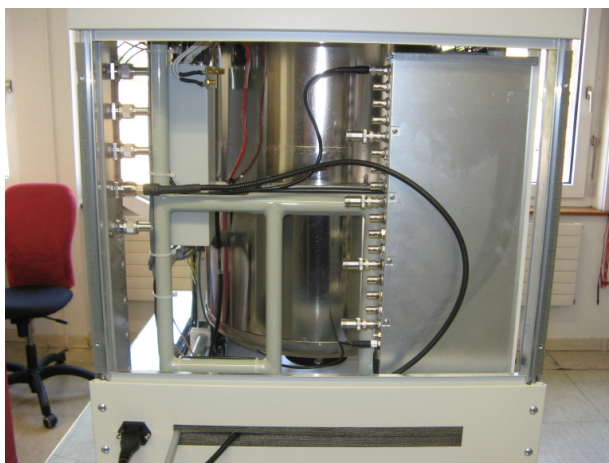

Figure 13: Frequency & 1 PPS Distribution

5.4.5. Parameter Connectors

5.4.5.1. Analog outputs, Front Panel connectors

Four “BNC” connectors deliver DC voltage signals for monitoring on the Front Panel (Figure 14). They are used for servicing.

- The Maser amplitude "Ampl. 405 kHz" gives information on the atomic power at the receiver; the calibration is given for each Maser.
- The cavity Varactor voltage "Varactor" gives information on the microwave cavity frequency; the calibration is given for each Maser.
- The molecular Hydrogen pressure "Meas H" gives information on the Hydrogen pressure in the H source; the calibration is given for each Maser.
- The ambient temperature "Amb. Temp." gives information on ambient temperature (external LM35 probe); the calibration is 10 mV/°C.



Figure 14: Front Panel with Control LEDs, Parameter Outputs & Adjustment



5.4.5.2. RS232 interface, Front Panel SUB-D connector

A connector (SUB-D9 male type) placed on the Front Panel allows for parameter control via a RS232 line and a software delivered with the Maser (5.5). Connection to the PC is made via port com1 or com2. The pin assignment is given in Table 1.

<i>Pin N°</i>	<i>Signal</i>
2	Transmit RS232
3	Receive RS232
5	GND RS232

Table 1: Monitoring RS232 line, SUB-D9 pin assignment

5.4.5.3. Analog inputs, connectors placed in the rack

Two connectors for input signal are placed in the rack. They are used for servicing.

- The Zeeman coil input, "SMA" connector
- The inhibit HF oscillator modulator, "SUB-D" connector

5.4.6. Physical Parameter Adjustments

Three physical parameters of the Maser can be adjusted for servicing.

- The cavity frequency can be tuned within a range of typically 10 kHz with the cavity Varactor. The cavity Varactor voltage (0 to 10 V) is controlled with the Front Panel potentiometer "Varactor" (Figure 14).
- The molecular Hydrogen pressure filling the Dissociator can be adjusted with the "beam stabiliser" system which regulates a Nickel valve by heating. Refer to chapter 11.3 for more details.
- The atomic flux for a given molecular Hydrogen pressure can be adjusted by varying the power of the HF oscillator exciting the plasma in the Dissociator. Refer to chapter 11.4 for more details.

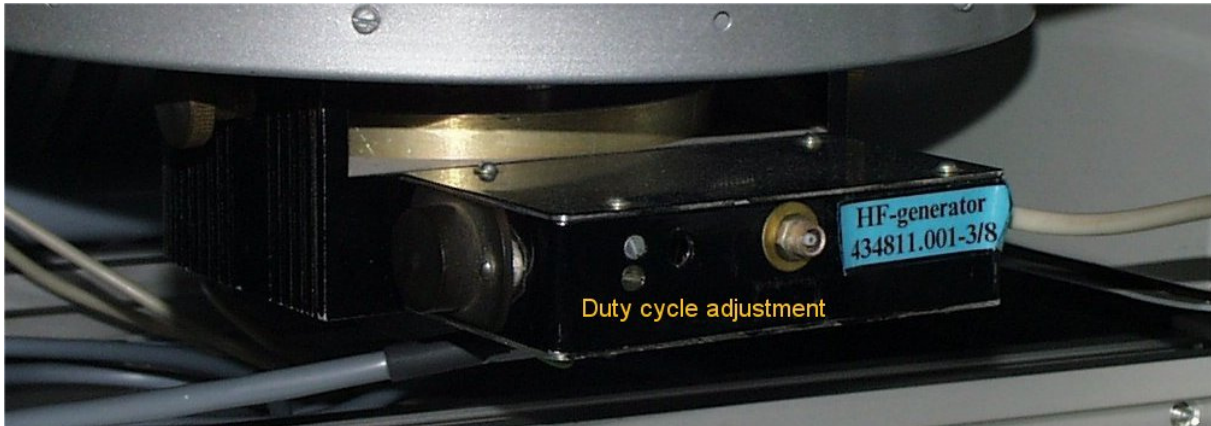

Figure 15: HF Oscillator Adjustment (Dissociator in the Rack)

5.4.7. Control LEDs

Close to the Front Panel connectors, two LEDs allow for controlling the Dissociator and the Lock status (Figure 14). The Dissociator LED is lighting when the discharge is present in the Dissociator. The Lock LED is lighting when the OCXO is locked to the Maser signal.

Presence of power at the connector level is verified by control LEDs (5.4.2). After temporary power supply failure, a power alarm light will flash when the Maser is powered again. The alarm LED is manually reset by simple pressure.

5.4.8. Out of lock relay

An out of lock relay connector (BNC type) is available on the rear distribution panel.

The operational state is CLOSED. Any alarm will change the state to OPEN





5.5. Monitoring & Control Concept

Through a RS232 line and a standard protocol, the main parameters of the Maser can be monitored continuously (nominal update rate: 1 per second).

The software delivered with the Maser runs under PC-DOS/Windows environment (PC is not delivered). It allows the visualisation of data on screen, the adjustment of the main synthesiser frequency and recording on disk files (for further transfer via email,...).

5.5.1. Parameter Monitoring

The monitored parameters include:

- the input voltages and currents powering the Maser as well as the internal DC/DC converters status
- the Hydrogen distribution parameters (storage Hydrogen pressure, Hydrogen pressure in the source,...)
- the internal heaters of the Maser
- the ion pump parameters
- the cavity Varactor voltage
- the OCXO Varactor voltage
- the Maser atomic amplitude signal
- the Lock status of the PLL
- the ambient temperature (with a temperature probe delivered with the maser)

The list of the 40 parameter channels are given in Table 2, the 32 first have a resolution of 12 bits resolution and the last a resolution of 8 bits.

In addition to the 40 parameter channels, the Lock status of the main PLL (1 or 0) and the synthesiser frequency (405'708 to 405795 Hz) are available.

Channel	Description	Name	ADC full scale	Gain [physical unit/LSB]
1	Battery voltage A	U batt.A [V]	4096	2.441E-02
2	Battery current A	I batt. A [A]	4096	1.221E-03
3	Battery voltage B	U batt.B [V]	4096	2.441E-02
4	Battery current B	I batt. B [A]	4096	1.221E-03
5	Hydrogen pressure setting	Set. H [V]	4096	3.662E-03
6	Hydrogen pressure measurement	Meas. H [V]	4096	1.221E-03
7	Purifier current	I purifier [A]	4096	1.221E-03
8	Dissociator current	I dissociator [A]	4096	1.221E-03
9	Dissociator light	H light [V]	4096	1.221E-03
10	Internal top heater	IT heater [V]	4096	4.883E-03
11	Internal bottom heater	IB heater [V]	4096	4.883E-03
12	Internal side heater	IS heater [V]	4096	4.883E-03
13	Thermal control unit heater	UTC heater [V]	4096	4.883E-03
14	External side heater	ES heater [V]	4096	4.883E-03
15	External bottom heater	EB heater [V]	4096	4.883E-03
16	Isolator heater	I heater [V]	4096	4.883E-03
17	Tube heater	T heater [V]	4096	4.883E-03
18	Boxes temperature	Boxes temp. [°C]	4096	2.441E-02
19	Boxes current	I Boxes [A]	4096	1.221E-03
20	Ambient temperature	Amb. Temp. [°C]	4096	1.221E-02
21	C-field voltage	C field [V]	4096	2.441E-03
22	Varactor voltage	U varactor [V]	4096	2.441E-03
23	external high voltage value	U HT ext. [Kv]	4096	1.221E-03
24	external high voltage current	I HT ext. [uA]	4096	1.221E-01
25	internal high voltage value	U HT int. [kV]	4096	1.221E-03
26	internal high voltage current	I HT int. [uA]	4096	1.221E-01
27	Hydrogen storage pressure	Sto. press. [bar]	4096	4.883E-03
28	Hydrogen storage heater	Sto. heater [V]	4096	6.104E-03
29	Pirani heater	Pir. heater [V]	4096	6.104E-03
30	Unused	Unused []	4096	0.000E+00
31	405 kHz Amplitude	U 405 kHz [V]	4096	3.662E-03
32	OCXO varicap voltage	U ocxo [V]	4096	2.441E-03
33	+24 V supply voltage	+24Vdc [V]	256	9.766E-02
34	+15 V supply voltage	+15Vdc [V]	256	7.813E-02
35	-15 V supply voltage	-15Vdc [V]	256	-7.813E-02
36	+5 V supply voltage	+5Vdc [V]	256	3.906E-02
37	-5 V supply voltage	-5Vdc [V]		Not used
38	+8 V supply voltage	+8Vdc [V]	256	3.906E-02
39	+18 V supply voltage	+18Vdc [V]	256	7.813E-02
40	Unused	Unused []	256	0.000E+00

Table 2: List of the Monitoring Channels with their Resolution

5.5.2. Main Frequency Synthesiser

The frequency of the outputs can be adjusted with the following characteristics:

- Frequency setting range: $\pm 3 \cdot 10^{-8}$, corresponding to a synthesizer frequency between 405'708 and 405'795 Hz



- Frequency setting resolution: $6.4 \cdot 10^{-15}$, corresponding to a synthesizer frequency resolution of 9.09 μ Hz.

5.5.3. Data Transfer Protocol

5.5.3.1. Format and commands

Baud rate: 9600 Bit/S, No parity, 8 data bits, 1 start bit, 1 stop bit.

The commands are listed on Table 3.

Note: The commands related to ACT concern options not available for these Masers.

Command	Effect	Answer (hexa)
RXX(CRLF)	Read RAM at address XX	1 byte + CRLF
WXXYY(CRLF)	Write data YY at address XX in the RAM	No
V(CR)	Software version and checksum of the microprocessor	Software : MS6A 31/01/00 checksum 0157/FE00 +CRLF
U(CR)	Activation of synthesizers with new parameters	No
Y(CRLF)	Activation of the ACT	No
N(CRLF)	Deactivation of the ACT	No
M (CRLF)	Reading of the 40 analog channels and Lock status (1 single string of 113 bytes)	Channels 1 to 32: 3 bytes + Channels 33 to 40: 2 bytes + Lock status: 1 or 0 + CRLF
F(CRLF)	Reading of the frequency synthesizers and ACT registers	Channels 00 to 0D + ACT status + CRLF

Table 3: List of Commands

5.5.3.2. Frequency registers

The frequency registers are given in Table 4.

Note: The commands related to ACT concern options not available for these Masers. This means that only registers “00” to “03” can be are used.



Register	Function	Register	Function
00	Synth (MSB)	0E	Mod per. MSB
01	Synth (2èmeB)	0F	Mod per. LSB
02	Synth (3èmeB)	10	PLL off MSB
03	Synth (LSB)	11	PLL off LSB
04	ACT low base1 (Fixed: 32)	12	Sampling MSB
05	ACT low base2 (Fixed: C0)	13	Sampling LSB
06	Nlow	14	Inter-sampl MSB
07	Nlow	15	Inter-sampl LSB
08	Alow	16	PLL off-inter MSB
09	ACT high base1 (Fixed: 32)	17	PLL off-inter LSB
0A	ACT high base2 (Fixed: E6)	18	Inter. MSB
0B	Nhigh	19	Inter. LSB
0C	Nhigh		
0D	Ahigh		

Table 4: Frequency & ACT Registers

5.5.3.3. Frequency synthesiser calculation

The main synthesiser frequency \$FM is stored in the 4 first bytes of the register (00, 01, 02 and 03) of the Table 4 the others must not be used.

The reference value \$FM0 is: \$63'21'37'88 (\$00=\$63, \$01=\$21, \$02=\$37, \$03=\$88). \$FM0 corresponds to the maser frequency Fmas=1'420'405'751.00000 Hz.

The synthesizer resolution (1 LSB) corresponds to

$$dF_{mas} = \frac{5MHz}{2^{39}} = 9.09495 \cdot 10^{-6} Hz \text{ (or } dy = 6.40 \cdot 10^{-15} \text{ in relative frequency).}$$

The calculation of the maser frequency is then:

$$F_{mas} = 1'420'405'751.0 + (FM - FM0) \cdot 9.09495 \cdot 10^{-6} Hz$$

(FM and FM0 are respectively the decimal values of the corresponding \$FM and \$FM0 hexadecimal values !)

Example : \$FM=\$63'22'5F'14, \$FM-\$FM0=\$1278C (hexadecimal), FM-FM0=75'660 (decimal), Fmas=1'420'405'751 + 75'660 · 9.09496 μHz, Fmas=1'420'405751.688124 Hz



6. Maser Specifications

6.1. Electrical Interfaces

6.1.1. Sine Outputs

The two 5 MHz signal, and two 100 MHz and the 10MHz output signal are directly derived from the OCXO (5 MHz). The connectors are all of type "N".

Outputs	Level (50 ohm)	Isolation	Spectral purity (2nd harmonic)	Spectral purity (spurious)
5 MHz (2 outputs)	13 dBm	≥ 80 dB	≤ -40dB	≤ -70dB
10 MHz (4 outputs)	13 dBm	≥ 80 dB	≤ -40dB	≤ -70dB
100 MHz (2 outputs)	13 dBm	≥ 80 dB	≤ -40dB	≤ -70dB

Table 5 : Sine Output Signals: 5 & 100 MHz



6.1.2. 1 Pulse per Second Output

The 1 PPS (pulse per second) clock, locked on the Maser consists of a digital clock (LCD display) and a pulse generator.

The digital clock readout include the following adjustable data:

- month, year, day of week, hour, minute, second

The 1PPS signal characteristics is available through a “BNC” connector (Table 6) and located on the rear panel see **Figure 13**.

Connector type:	1BNC
Frequency output:	1Hz
Output impedance:	50 ohm
Output levels:	2 Volt / 50 Ohm
Rise and fall time:	<5 ns
Time reference:	rising edge
Pulse duration:	100 us
output advance/retard correction steps	100 mS, 10 mS, 1 mS, 100 μS, 10 μS, 1μS, 100 nS and 50 nS

Table 6 : 1 PPS Output

The 1 PPS can be synchronised to an external signal reference through a "BNC" type connector (Table 7) and located on the front panel see **Figure 10**.

Connector type:	1BNC
Input impedance:	50 ohm
Reset input level:	2 to 5 Volts
Reset input duration	> 20 ns
Time reference:	rising edge

Table 7 : 1 PPS Reset



6.1.3. Power Consumption

Power (normal operation)	< 200 VA @230V, typically 84W @ 22V-32V <4A
Power (standby: ion pumps and heater)	< 60 VA @230V, typically 30W @ 22V-32V <1A

Table 8: Power Consumption

Note: the DC voltage will be supplied by the UPS delivered with the Masers. The Spare batteries can be connected in parallel for doubling the duration of maintain power for transportation.

6.2. Mechanical Characteristics

The Maser is integrated in a standalone rack mounted on a trolley with the following dimensions:

Width:	60 cm
Depth:	80 cm
Height:	total height: 120 cm rack alone: 87 cm amortising feet: 4 cm
Trolley & wheels (optional)	71 x 112 x 29cm
Weight: Maser	110 kg
Weight: Trolley (Option)	40 Kg
Weight: Batteries (Batterie)	40 Kg

Table 9: Mechanical Characteristics



6.3. UPS (Optional)

The UPS consists of a battery set and one battery charger (24 V).

A battery set consists of 2 batteries of 12 V mounted in a wheeled battery box with associated cables, connectors, and fuse.

The spare battery set consists of 2 batteries of 12 V mounted in a wheeled battery box with associated cables, connectors, and fuse.

6.3.1. Battery Type

The batteries are all of the same type:

- Manufacturer: Sonnenschein GmbH, 63654 Büdingen, Deutschland, "<http://www.sonnenschein.org/>"
- Type: Dryfit A500
- Model: A512/55A, with a capacity of 55 Ah, dimensions: 261x135x230 mm, 19 kg
- Temperature range (operating): -20 to +50 °C

This type of sealed batteries is maintenance free and position independent. The electrolyte is immobilised in a gel to guarantee optimum reliability and a long life (6 years).

They are suitable for standby operation (use for UPS) and for cycling (600 cycles of charge and discharge).

They are safe for transportation (road, rail and even air, in accordance to IATA) and support high pressure ranges (30 hPa to 4000 hPa).

6.3.2. Battery Sets

The batteries are installed in a wheeled box with fuse.

The output connexion cable have a 1.5 mm² section.

Type of the battery box:

- Manufacturer: Georg Utz Holding AG, 5620 Bremgarten, Switzerland, "<http://www.utz.ch/E/>"
- Type: RAKO, type 3-212U0 and 3-214N111, mounted on trolley type 80-270-0
- Dimensions: w=40 cm, d=30 cm, h=41 cm (including the trolley)

6.3.3. Battery Charger

- Manufacturer: Sonnenschein GmbH, 63654 Büdingen, Deutschland, "http://www.sonnenschein.org/"
- Type: Konstant 24-8/12
- Temperature range: operating: 0 to +35 °C; non-operating: -10 to +70 °C

This type of charger is suitable for the Dryfit batteries and allows for charging and maintaining power for UPS applications.

The power line connector is of IEC-320 type.

Note: The battery charger will be fixed on the top of the battery box.

6.3.4. Powering in Nominal Operation

In nominal operation, the Maser is powered in parallel by the 230 V main line through the AC power input ("B") and the UPS through the DC power of the main power supply distribution unit. The AC/DC transformer integrated in the Maser will be adjusted in order to provide a DC voltage slightly larger than the UPS.

In case of main line failure, the UPS will maintain the power for more than 10 hours (55Ah, current < 4 A).

The Figure 16 represents schematically the AC and DC connections.

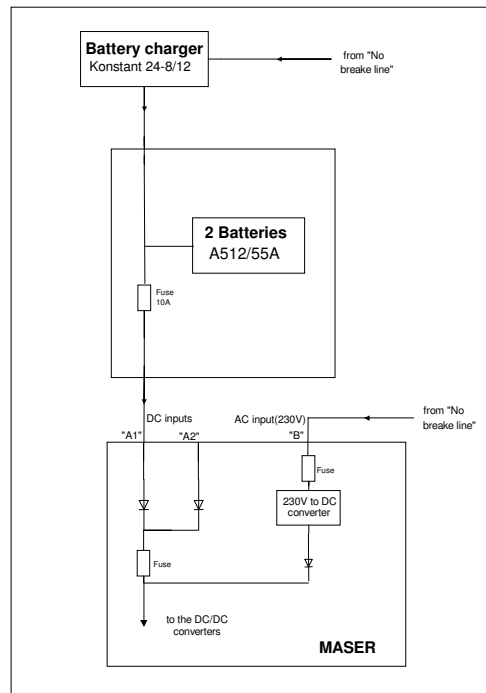

Figure 16: UPS & 230 V Main Line Connected to the Maser (Nominal Operation)

6.3.5. DC Power Supplies in Parallel

To double the DC power capacity (transportation or risk of long period without AC power), it is possible to connect the spare battery set in parallel with the UPS.

In Figure 17, power connections are shown with the UPS and the Spare battery set.

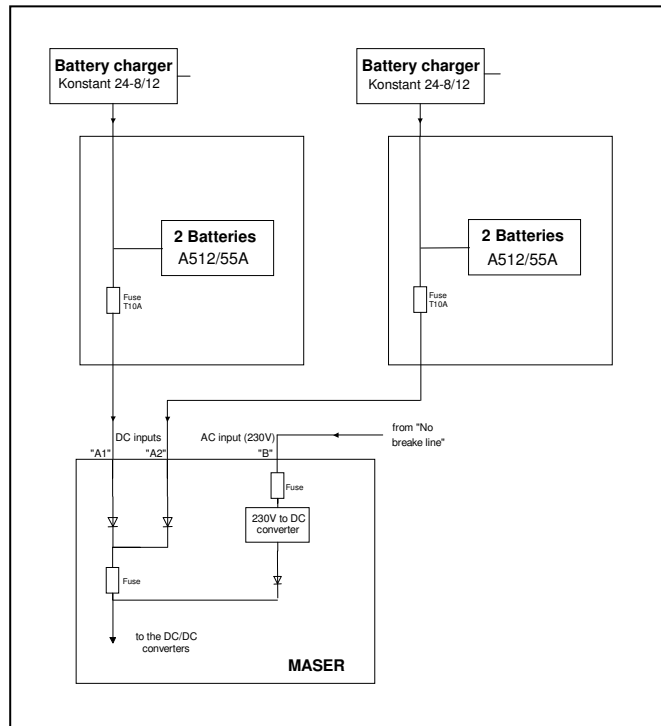

Figure 17: UPS & Spare Batteries Connected to the Maser (Transportation)

6.3.6. Verification of the UPS Batteries

A safe way to verify the UPS batteries is to decrease the DC voltage of the transformer integrated in the Maser down to 22V and to switch-off the UPS charger (the access to the transformer output voltage requires only the opening of a panel). This will force the discharging of the batteries up to a minimum of 22V. The discharge time will give information on the battery status.



6.3.7. Spare Batteries & Replacement

On site, the Spare batteries can be stored without permanent loading.

First, the Spare batteries set must be charged. During loading, the Spare set can be connected to the Maser in parallel with the UPS set. After loading of the Spare set, the UPS set can be disconnected from the Maser.



7. Powering the Maser

Although it is possible to switch-off completely the instrument, it is highly recommended to store or transport it under standby conditions.

In the standby mode, only the heaters (cavity temperature,...) and the ion pumps which insure the vacuum are operating. The Hydrogen distribution and the main electronics can be switched off to spare a maximum of power.

If the Maser is completely switched-off, the time required to stabilise the cavity temperature is increased. Moreover, there are risks that the degradation of the vacuum due to the stopping of the ion pumps cannot be recovered with the standard switch-on procedure of the instrument.

8. Starting Procedure (Standby to Operating Mode)

This chapter describes the procedure for starting the instrument from standby to operating mode. The Maser is then assumed to be powered (DC, AC or both types and key-switch on).

The procedure should be followed point by point. Particular care should be taken before starting the discharge in the Dissociator: To prevent degradation of the Dissociator bulb, **the RF oscillator/HF generator should not be operating without Hydrogen.**

1. Prepare the logbook of the instrument to read the status of the previous operating conditions and record the actions, parameters and changes
2. Switch-on the HF receiver: "HF rcvr" switch
3. Start the monitoring program, including the recording with a sampling period of 100 seconds for the first hours of operations
4. Switch-on the Beam stabilizer: "Beam stab" switch.
5. Wait until purifier current "Ipur" and Hydrogen pressure "Meas.H" are stable and close to the previous conditions of operations (this takes usually 15 minutes).
 - If "Ipur" is too low, verify that the setting point "Set H" corresponds well to the previous conditions of operations.
 - It is possible to adjust "Ipur" with the Front Panel potentiometer close to the "Meas H" connector (Figure 14 and chapter 11.3).



6. Switch-on the RF oscillator/HF generator: “RF osc” switch and observe the LED indicator for the Dissociator activity on the Front Panel.
 - Depending on the switch-off duration of the beam stabilizer and RF oscillator/HF generator, the discharge can take several minutes before starting.
 - The light intensity of the discharge is measured by the light sensor (“H light”).
7. Once the discharge has started, atomic signal should be detected at the receiver:
 - The "A405 kHz Amplitude" of the monitoring and the Front Panel output (Figure 14) will be non zero.
 - The Lock status of the OCXO/PLL can be verified at the monitoring and the associated LED (Figure 14).
 - Depending on the switch-off duration of the HF receiver, the atomic signal and Lock status can take several minutes to be present.

Note: If the Lock status is not present, the most probable reason is a out of PLL capture range condition: the OCXO frequency is too far away from the maser frequency to be locked. In this case there are two ways to get back the Lock:

 - a) switch-off HF receiver ("HF rcvr") for 5 seconds and switch it on again: when switching-off shortly the receiver, the PLL error signal feeding the OCXO
 - b) adjust gently the mechanical tuning of the OCXO (trimmer on the side of the OCXO)
8. After several hours of operation, increase the sampling period of the monitoring to 1000 seconds or more.



9. Switch-Off Procedure (Operating to Standby Mode)

This chapter describes the procedure to switch-off the instrument from operating to standby mode. The Maser is then assumed to be kept powered (DC, AC or both types).

The procedure should be followed point by point. Particular care should be taken before switching-off the Beam stabilizer: To prevent degradation of the Dissociator bulb, **the RF oscillator/HF generator should not be operating without Hydrogen.**

1. Prepare the logbook of the instrument to record the status of the present operating conditions and record the actions, parameters and changes.
2. Switch-off the RF oscillator/HF generator: "RF osc" switch and observe the LED indicator for the Dissociator activity on the Front Panel.
3. Switch-off the Beam stabilizer: "Beam stab" switch.
4. Stop the monitoring program (only for Serial RS232)
5. Switch-off the HF receiver: "HF rcvr" switch.

10. Transportation Under Power Conditions

During transportation, the Maser will be in a standby mode requiring less current than in nominal mode. The UPS will be sufficient for more than 30 hours (55Ah, current < 1.25A). It is foreseen to connect the Spare batteries to the Maser in parallel with the UPS to double the capacity. In Figure 17, power connections are shown with the UPS ("A1") and the Spare battery set ("A2"). The access to the charger main line (230V) will be free to allow the battery recharging during temporary storage.

10.1. Operating to Standby Mode

The Nickel purifier being fragile, it is highly recommended to switch-off the beam stabilizer (Front Panel switch) before transportation. However, to prevent degradation of the Dissociator bulb, the RF oscillator/HF generator should be switched off before switching-off the beam stabilizer.

Procedure described in chapter 9 should be followed.

10.2. Logbook & Handling

Due to the limited capacity of the batteries and the fragility of the equipment, trained people should follow and note in the dedicated logbook the major events: installation in the transport box, date and time of charger disconnection,...

10.3. Installation in the Transport Box

After switching in standby mode (low power conditions), the Maser can be installed and fixed in the transport box while the UPS remains connected.

The DC power cables must be long enough to manipulate independently the UPS, the Spare batteries and the Maser. Two people can handle the instruments

The Spare batteries can be connected in parallel with the UPS to double the capacity and the main line (230 V) can be removed.

After closing the transport box with the cover, the system will be ready for shipment (Figure 18).

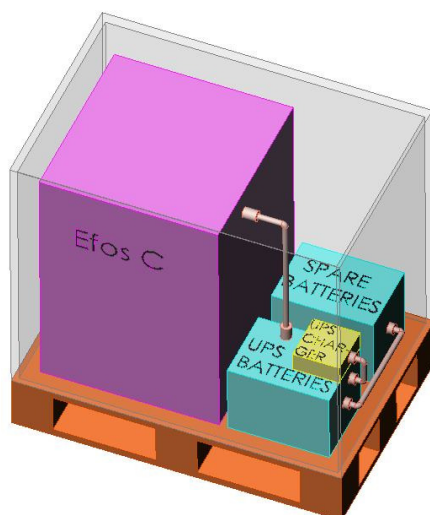

Figure 18: Schematic View of a Transporting Box with UPS & Spare Batteries

Due to the weight the handling of the transport box requires a fork-truck.

In case of temporary storage, the charger can be powered (230V) without removing the cover to Spare battery capacity.



10.4. Maser Installation

Caution!

The installation of the Maser must be performed by T4S staff exclusively.

After transportation, the box should be visually inspected: pallet, cover, shock recorders, power alarm light (5.4.2),... Any default should be written in the logbooks.

Room specification:

Special attention should be paid to the following environment parameters:

Temperature & air conditioning

Temperature shall be as stable and uniform as possible inside the operating range. Air conditioning outlet, temperature changes due to windows or door opening shall be reduced. Typical stability +/- 0.2°C is recommended!

Vibration:

The Maser shall be installed on a stable surface so as to avoid the propagation of vibration. The sensitivity to high frequency shocks or vibrations (>1Hz) shall not reach the Maser.

Magnetic fields

The Maser shall be kept away from perturbing magnetic fields, generated by any electrical systems (eg. High current machine, lifts elevators, motors, railroad and bus transportation. We recommend maximum +/- 0.02 Gauss.

Mains stability

A cold start of the Maser requires 250 Watts during at least 1 day upon complete stability. During normal operation refer to 6.1.3

Powering up.

The charger can be powered again (230V) as soon as possible to spare battery capacity.

The instrument still powered in standby mode will be removed from the box and installed on the wheeled trolley before installation in the Maser room. During this phase, the UPS remains connected. But the Spare batteries and the main power line (230V) can be disconnected.

The Maser will then be ready for returning in operating mode following the step by step procedure (8). The Maser and UPS can be finally rolled in the Maser room for the final connections (main power line, 5 MHz, 1 PPS,...).



11. Operating & Calibration Check

11.1. Adjustment of the Frequency Synthesizer

The frequency synthesizer is used to adjust the output frequency ν_0 of the Maser available at the Front Panel connectors, without changing the physical parameters like the cavity resonance frequency which would change the frequency F_{out} of the atomic signal delivered at the low noise receiver input (chapter 13.1.5).

The monitoring program describes how to change the data themselves. This chapter gives the relation between the Maser output frequency and the synthesizer frequency. Notice particularly the **negative sign of Eq. 6**.

The action of the synthesizer frequency is as follows (Figure 5):

The output of the synthesizer is phase compared to the Maser signal coming out from the 405kHz last stage down-converter IF_3 . The PLL error signal is applied to the 5 MHz OCXO and forces IF_3 to be exactly equal to the synthesizer frequency ν_{synth} .

The first IF frequency in the down-conversion is $IF_1=20.405$ MHz using a 1400 MHz local oscillator derived by multiplication ($280\times$) from the 5 MHz OCXO frequency ν_{ocxo} :

$$\text{Eq. 1} \quad IF_1 = F_{out} - 280 \times \nu_{ocxo}$$

The second IF frequency in the down-conversion is $IF_2=4.59$ MHz using a 25 MHz local oscillator derived by multiplication ($5\times$) from the 5 MHz OCXO frequency ν_{ocxo} :

$$\text{Eq. 2} \quad IF_2 = 5 \times \nu_{ocxo} - IF_1 = 285 \times \nu_{ocxo} - F_{out}$$

The third and last IF frequency in the down-conversion is $IF_3=405$ kHz using a 5 MHz local oscillator derived from the 5 MHz OCXO frequency ν_{ocxo} :

$$\text{Eq. 3} \quad IF_3 = \nu_{ocxo} - IF_2 = F_{out} - 284 \times \nu_{ocxo}$$

In the Lock condition, the relation becomes:

$$\text{Eq. 4} \quad \nu_{synth} = IF_3 = F_{out} - 284 \times \nu_{ocxo}$$

The output frequency of the Maser ν_0 being the OCXO signal ν_{ocxo} amplified, it is directly given by:



$$\text{Eq. 5} \quad v_0 = v_{ocxo} = \frac{1}{284} \times (F_{out} - v_{synth})$$

Therefore, the relative output frequency offset Δy_0 produced by a synthesizer frequency step Δv_{synth} is given by:

$$\text{Eq. 6} \quad \Delta y_0 = \frac{\Delta v_0}{v_0} = \frac{-\Delta v_{synth}}{284 \times 5 \text{ MHz}} = \frac{-\Delta v_{synth}}{1.42 \cdot 10^9}$$

Notice the negative sign of the relation.

11.2. Adjustment of the 1 PPS Clock

The 1 PPS (pulse per second) clock locked on a 5 MHz output of the 5 MHz distribution unit consists of two distinct parts :

- digital clock
- 1 Hz pulse generator

11.2.1. Digital Clock

The digital clock uses the two first lines of the display. The first line shows Hours, minutes and seconds while the second line shows date, month, year and the day of the week.

To modify a clock value, move the cursor under the desired digit by pressing the cursor button. Each time the cursor button is pressed, the displayed cursor moves to the next digit at the right. From the end of a line, the cursor jumps to the next line.

Once the cursor is under the desired digit, increase or decrease the digit value by pressing the + or - button. with the cursor positioned under the symbol %, + and - buttons will shift the clock by tens of seconds.

Day of week convention : 1 = Monday, 7 = Sunday.



11.2.2. 1 Hz Pulse

The 1 Hz outputs pulse can be shifted in the same manner as the digital clock is set. Move the cursor under the digit to modify, press + to retard the 1 Hz pulse or - to advance. The selected digit is incremented if the pulse is retarded (+) and decremented if the pulse is advanced (-). The finest shift step is 50 nS.

The display accumulates all the shifts applied to the 1 Hz pulse. The display represents the time interval between the original 1 Hz pulse (when the display was « 000 000 000 ») and the actual 1 Hz pulse.

The symbol « * » at the end of the line indicates that the module accepts corrections. This symbol toggles to « . » when the module is executing a shift (visible only when you apply 100 mS correction steps which takes about 5 seconds to complete). No further shifts are accepted during the « . » state.

The Reset IN BNC is used to synchronise the 1 Hz pulse on an external positive edge. The reset IN also resets the displayed pulse shift. If the 1 Hz output is connected to the Reset in input, The display is set to 000 000 000 without shifting the 1 Hz pulse.

11.3. Adjustment of the Molecular Hydrogen Flux

The molecular Hydrogen flux is controlled by the "Beam Stabilizer" system (5.2.1).

The molecular Hydrogen pressure filling the Dissociator can be adjusted with the "beam stabiliser" system which regulates a Nickel valve by heating. The setting point is controlled with the Front Panel potentiometer close to the "Meas H" connector (Figure 14). The setting point value is readable as monitoring channel "Set H".

The actual value delivered by a Pirani pressure sensor is readable as monitoring channel "Meas H" and DC voltage at the "Meas H" output connector.

The corresponding current heating the Nickel purifier valve is readable as monitoring channel "Ipur".

Notice the negative slopes between the 2 parameters "Set H" and "Meas H".

The molecular Hydrogen flux increases with increasing purifier current. To a certain extend, the atomic flux, and then the atomic output signal, follows the Hydrogen flux.



11.4. Adjustment of the Discharge HF Oscillator

The Hydrogen atoms are produced in a plasma discharge. For a given molecular Hydrogen pressure, the dissociation yield, and then the atomic flux, changes with the power of the HF oscillator exciting the plasma in the Dissociator. To a certain extent, the atomic Hydrogen flux increases with increasing HF oscillator power.

Practically the HF oscillator frequency, close to 100 MHz, is square modulated and the power can be adjusted by changing the duty cycle of the modulation. This is done with the potentiometer of the HF oscillator installed in the rack (Figure 15).

In addition to this adjustment, it is also possible to inhibit the modulation in order to put the full HF oscillator power. Practically, this is done with a DC voltage of +5V applied between the pin 2 and 4 of the SUB-D9F connector of the HF oscillator. The "HF oscillator remote control" allows to inhibit the modulator. It must be powered with a 5V DC supply.

Note: Adjusting the HF oscillator requires the opening of the rack back panel fixed with 6 screws.

11.5. Evaluation of the Maser Quality Factor

The atomic quality line factor Q_L is evaluated through the pulling factor K_p (Eq. 12).

The Maser output frequency F_{out} is measured for different cavity frequencies (chapters 5.4.6).

Note: for a fixed synthesizer frequency, all relative frequencies are equal to the output frequency F_{out} . F_{out} can then be determined from the user output frequencies at the Front Panel.

The pulling factor being typically $K_p = 3 \cdot 10^{-5}$, a cavity frequency change of $\Delta F_C = 1 \text{ kHz}$ corresponds to a typical output frequency change of $\Delta F_{out} = 30 \text{ mHz}$ or $\frac{\Delta F_{out}}{F_{out}} > 2 \cdot 10^{-11}$ in relative frequency. Measurements with averaging time τ of 10 seconds is sufficient if the reference standard is a second Maser .

The quality line factor depends mainly on the Hydrogen flux. It will be then useful to record the Hydrogen flux conditions: monitoring channels "Set H", "Meas H", "Ipur", "Idiss" and "A405".

For each frequency F_{out} measured, the Varactor voltage "Varactor" and the Maser amplitude "Ampl. 405 kHz" will be measured at the Front Panel (Figure 14) to



determine precisely the cavity frequency and the atomic power level with the calibration curves.

The frequency F_{out} will be graphically represented in function of the cavity frequency F_C . From this curve, the pulling factor and the quality line factor will be determined.

The atomic power will be graphically represented in function of the cavity frequency F_C . From this curve, the maximum of atomic power level and the corresponding cavity frequency tuning $F_C(Max)$ will be determined.

11.6. Evaluation of the Spin Exchange Tuning

Three particular tunings of the cavity can be used for optimising different parameters of the maser: The "Spin Exchange" tuning $F_C(SE)$, the "Maximum of amplitude" tuning $F_C(Max)$ and the "Magnetic Tuning" $F_C(Mag)$.

Usually, the cavity is tuned at the so called "Spin Exchange". This tuning makes the maser frequency the less sensitive to Hydrogen flux variations. This tuning can differ from the "Maximum amplitude" tuning and the "Magnetic Tuning" by several hundreds of Hertz.

The method used to determine the "Spin Exchange" tuning requires to have a second maser for reference. In absence of a reference maser, the cavity is tuned at the "Maximum amplitude" frequency

The influence of Hydrogen flux on the maser frequency F_{out} is evaluated for several cavity frequencies F_C . The extrapolation of the cavity frequency for which the influence of the Hydrogen flux is minimum is then determined as $F_C(SE)$.

For each cavity frequency F_C (Varactor), the output frequency is measured at two different Hydrogen flux conditions: $F_{out}(high)$ and $F_{out}(low)$ (low and high fluxes). The Varactor voltage "Varactor" and the Maser amplitude "Ampl. 405 kHz" will be measured at the Front Panel (Figure 14) to determine precisely the cavity frequency and the atomic power level with the calibration curves.

To set the low flux condition, the discharge HF oscillator will be adjusted at a low duty cycle with the corresponding potentiometer. To swap rapidly to the high flux condition, the "HF oscillator remote control" will be used.

Note: before adjusting the HF oscillator, the initial Hydrogen flux conditions will be recorded in the logbook: monitoring channels "Set H", "Meas H", "Ipur", "Idiss" and "A405".§

The frequency difference $\Delta F_{out} = F_{out}(high) - F_{out}(low)$ will be graphically represented in function of the cavity frequency F_C . From this curve, the "Spin Exchange" tuning is determined as the cavity frequency for which

$$\Delta F_{out} = F_{out}(high) - F_{out}(low) = 0.$$



12. Nominal Ranges & Alarms Condition

No.	Description	Name	Optimum	Green	Orange	Red	Non-working Condition (only in case of monitoring channel operating)
	<small> ¹ Power supply voltage could operate in single mode, the highest voltage is prime supply: A or B or A+B, ² Power supply current are additive A+B </small>						
1	Battery voltage A or B ¹⁾	U batt.A [V]	[26, 28]	[22, 30]	[18, 22] or [30, 31]	<18 or >31	<10
2	Battery current A+B ²⁾	I batt. A [A]	[2.5, 3.5]	[1.5, 4]	[1, 1.5] or [4, 4.5]	<1 or >4.5	<0.2
3	Battery voltage A or B ¹⁾	U batt.B [V]	[26, 28]	[22, 30]	[18, 22] or [30, 31]	<18 or >31	<10
4	Battery current A+B ²⁾	I batt. B [A]	[2.5, 3.5]	[1.5, 4]	[1, 1.5] or [4, 4.5]	<1 or >4.5	<0.2
5	Hydrogen pressure setting	Set. H [V]	[4.5, 6]	[2, 7.5]	[1, 2] or [7.5, 8]	<1 or >8	<0.2
6	Hydrogen pressure measurement	Meas. H [V]	[1, 2]	[0.5, 4]	[0.2, 0.5] or [4, 5]	<0.2 or >5	<0.1
7	Purifier current	I purifier [A]	[0.5, 0.7]	[0.3, 0.9]	[0.2, 0.3] or [0.9, 1]	<0.2 or >1	<0.1
8	Dissociator current	I dissociator	[0.1, 0.5]	[0.1, 0.5]	[0.05, 0.1] or [0.5, 0.6]	<0.05 or >0.6	<0.05
9	Dissociator light	H light [V]	[2, 4]	[1, 5]	[0.5, 1] or (>5]	<0.5 or >5	<0.05
10	Internal top heater	IT heater [V]	[5, 15]	[1, 19]	[0.5, 1] or [19, 20]	<0.5 or >20	
11	Internal bottom heater	IB heater [V]	[5, 15]	[1, 19]	[0.5, 1] or [19, 20]	<0.5 or >20	
12	Internal side heater	IS heater [V]	[5, 15]	[1, 19]	[0.5, 1] or [19, 20]	<0.5 or >20	
13	Thermal control unit heater	UTC heater [V]	[5, 15]	[1, 19]	[0.5, 1] or [19, 20]	<0.5 or >20	
14	External side heater	ES heater [V]	[5, 15]	[1, 19]	[0.5, 1] or [19, 20]	<0.5 or >20	
15	External bottom heater	EB heater [V]	[5, 15]	[1, 19]	[0.5, 1] or [19, 20]	<0.5 or >20	
16	Isolator heater	I heater [V]	[5, 15]	[1, 19]	[0.5, 1] or [19, 20]	<0.5 or >20	
17	Tube heater	T heater [V]	[5, 15]	[1, 19]	[0.5, 1] or [19, 20]	<0.5 or >20	
18	Boxes temperature	Boxes temp.	[40, 50]	[35, 60]	[30, 35] or [60, 65]	<30 or >65	
19	Boxes current	I Boxes [A]	[0.1, 0.5]	[0.05, 0.60]	[0.02, 0.05] or [0.6, 0.8]	<0.02 or >0.8	
20	Ambient temperature	Amb. Temp.	[21, 26]	[21, 29]	[0, 21] or [29, 40]	<0 or >40	
21	C-field voltage	C field [V]	[3, 7]	[3, 7]	[1, 3] or [7, 8]	<1 or >8	
22	Varactor voltage	U varactor [V]	[1.5, 8]	[0.5, 9.5]	[0, 0.5] or [9.5, 10]	<0 or >10	
23	external high voltage value	U HT ext. [Kv]	[3, 4]	[2.5, 4]	[1, 2.5] or [4, 5]	<1 or >5	
24	external high voltage current	I HT ext. [uA]	[1, 25]	[1, 90]	[0, 1] or [90, 150]	<0 or >150	
25	internal high voltage value	U HT int. [kV]	[3, 4]	[2.5, 4]	[1, 2.5] or [4, 5]	<1 or >5	
26	internal high voltage current	I HT int. [uA]	[1, 25]	[1, 90]	[0, 1] or [90, 150]	<0 or >150	
27	Hydrogen storage pressure	Sto. press.	[4, 15]	[2, 15]	[1, 2] or [15, 16]	<1 or >16	<1
28	Hydrogen storage heater	Sto. heater [V]	[5, 15]	[1, 19]	[0.5, 1] or [19, 20]	<0.5 or >20	
29	Pirani heater	Pir. heater [V]	[5, 15]	[1, 19]	[0.5, 1] or [19, 20]	<0.5 or >20	
30	Unused		N/A	N/A	N/A	N/A	
31	405 kHz Amplitude	U 405 kHz [V]	[7, 12]	[5, 12.5]	[1, 5] or [12.5, 13.5]	<1 or >13.5	<0.1
32	OCXO varicap voltage	U oxco [V]	[2.5, 7.5]	[0.5, 9.5]	[0, 1, 0.5] or [9.5, 9.9]	<0.1 or >9.9	
33	+24 V supply voltage	+24Vdc [V]	[23, 25]	[23.5, 25.5]	[22, 23.5] or [25.5, 27]	<22 or >27	<10
34	+15 V supply voltage	+15Vdc [V]	[14, 16]	[13.5, 16.5]	[12, 13.5] or [16.5, 18]	<12 or >18	<8
35	-15 V supply voltage	-15Vdc [V]	[-16, -14]	[-16.5, -13.5]	[-18, -16.5] or [-13.5, -]	<-18 or >-12	>-8
36	+5 V supply voltage	+5Vdc [V]	[4.8, 5.2]	[4.5, 5.5]	[3, 4.5] or [5.5, 7]	<3 or >7	<2
37	-5 V supply voltage	-5Vdc [V]	N/A	N/A	N/A	N/A	
38	+8 V supply voltage	+8Vdc [V]	[7.8, 8.2]	[7.5, 8.5]	[6, 7.5] or [8.5, 10]	<6 or >10	<2
39	+18 V supply voltage	+18Vdc [V]	[17, 19]	[16.5, 19.5]	[15, 16.5] or [19.5, 21]	<15 or >21	<10
40	Unused		N/A	N/A	N/A	N/A	
41	Main PLL lock status	Lock status	1	1	1	0	0



When a parameter status is upper the RED alarm condition, please contact the T4Science support team at FastSupport@T4Science.com.

13. Annexes

13.1. Maser Frequency Definitions

This chapter describes the different frequencies defined in the Maser:

- Unperturbed Hydrogen atom frequency ν_{HFS}
- Influence of magnetic field on atom frequency $\Delta\nu_B$
- Zeeman frequency ν_Z
- Hydrogen atom frequency in the Maser ν_H
- Cavity frequency F_C and output Maser frequency F_{out}
- User output frequencies ν_0

13.1.1. Unperturbed Hydrogen Atom Frequency

The unperturbed Hydrogen atom frequency results from the hyperfine structure transition of the fundamental atomic state levels ($F=1, m_F=0$ to $F=0, m_F=0$). Experimentally, the value is obtained after corrections of measured data from all known frequency offsets (cavity pulling, spin-exchange shift, magnetic shift, Teflon wall shift, second-order shift...).

$$\text{Eq. 7} \quad \nu_{HFS} = 1420'405'751.770 \pm 0.003 \text{ Hz} \quad (\text{Ref. 3})$$

13.1.2. Influence of Magnetic Field on Atom Frequency

The atomic energy states depending on magnetic field (Figure 1), the atomic frequency changes also with magnetic field. In the clock transition of the Maser levels ($F=1, m_F=0$ to $F=0, m_F=0$), the offset frequency related to the magnetic field B is quadratic dependent:

$$\text{Eq. 8} \quad \Delta\nu_B = K_0 \cdot B^2 \quad (\text{Ref. 3})$$

With
$$K_0 = \frac{1}{2 \cdot \nu_{HFS}} \left(\frac{(g_J + g_I) \mu_B}{h} \right)^2 = 2.773 \cdot 10^{11} \frac{Hz}{T^2}$$

Where g_J is the total electronic Landé factor, g_I the nucleus Landé factor, μ_B the Bohr magneton and h the Planck constant.

13.1.3. Zeeman Frequency

In practice, the magnetic field B can be measured with the help of the atomic states linearly field dependent ($F=1$, $m_F=\pm 1$, see Figure 1). Practically, this frequency is measured by applying a low level sweeping signal to the Zeeman coil. At the Zeeman frequency, the atomic amplitude decreases substantially.

The Zeeman frequency is given by:

Eq. 9
$$\nu_Z = K_Z \cdot B \quad (\text{Ref. 3})$$

With
$$K_Z = \frac{(g_J - g_I) \mu_B}{2 \cdot h} = 1.3991 \cdot 10^{10} \frac{Hz}{T}$$

13.1.4. Hydrogen Atom Frequency in the Maser

The Hydrogen atoms in the Maser are not in free flight. They are perturbed by the collisions with the Teflon coated walls, by the collisions between themselves, by magnetic non homogeneities, by relativistic effects,...

These perturbations shift the unperturbed Hydrogen atom emission by several part in 10^{11} .

The resulting frequency emitted by the atoms in the Maser is finally close to

Eq. 10
$$\nu_H = 1420'405'751.689 \text{ Hz}$$

13.1.5. Cavity Frequency & Output Maser Frequency

The excitation of the microwave cavity by the atomic signal corresponds to a two-resonator oscillator. The first resonator is the atom ensemble with a frequency ν_H and an atomic quality line factor Q_L . The second resonator is the cavity with a frequency F_C and a quality factor Q_C .

The resulting frequency F_{out} of the signal available at the output of the cavity (and input of the HF receiver) is given by:



Eq. 11
$$F_{out} = \nu_H + \frac{Q_C}{(Q_C + Q_L)} \cdot (F_C - \nu_H) \quad (\text{Ref. 3})$$

Q_C is generally omitted in the denominator because it is much smaller than the atomic quality line factor:

Eq. 12
$$F_{out} = \nu_H + \frac{Q_C}{Q_L} \cdot (F_C - \nu_H) = \nu_H + K_P \cdot (F_C - \nu_H)$$

Where K_P is the cavity pulling factor which characterizes the influence of the cavity on the output frequency.

Typically, $Q_L = 1.2 \cdot 10^9$, $Q_C = 4 \cdot 10^4$ and $K_P = 3 \cdot 10^{-5}$.

13.1.6. User Output Frequencies (Chapter 5.4.4)

The frequencies available for the user at the output connectors are derived from the OCXO frequency ν_{ocxo} locked to the Maser output signal F_{out} .

The 5 MHz main outputs refer to the frequency ν_0 .

A “one pulse per second” (1 PPS) signal characteristics is also available.

13.2. Frequency Stability

13.2.1. Definitions of the Allan Variance

This test characterizes the random frequency fluctuations of the maser output signal by the measurement of the Allan variance in the time domain. This measurement is meant to characterize the random frequency fluctuations to the exclusion of all the environmental effects.



The Allan variance is defined as

$$\text{Eq. 13} \quad \sigma^2(\tau) = \frac{1}{2} E\{(y_{k+1} - y_k)^2\}$$

where $E\{ \}$ is the statistical mean value operator, estimated in practice by time averaging N samples, and where the samples y_k are defined as the normalized frequency samples

$$\text{Eq. 14} \quad y_k = \frac{\nu_k [Hz] - \nu_0 [Hz]}{\nu_0 [Hz]}$$

produced by an ideal frequency counter that averages the frequency $\nu(t)$ over an interval τ without a dead time between successive samples. ν_0 is the oscillator nominal frequency.

The average frequency samples y_k may be computed from samples of the phase $\phi(t)$ or from samples of the time error function $x(t)$ if these quantities are measured instead of the average frequency over τ . The k^{th} sample may be written as

$$\text{Eq. 15} \quad y_k = \frac{1}{\tau} \int_{t_0+(k-1)\tau}^{t_0+k\tau} y(t) dt = \frac{1}{\tau} [x(t_0 + k\tau) - x(t_0 + (k-1)\tau)]$$

Both the time error $x(t)$ [s] and the phase noise process $\phi(t)$ [radian] are defined as the integral of the instantaneous frequency process $y(t)$. Only the units are different.

$$\text{Eq. 16} \quad x(t) = \frac{\Phi(t)}{2\pi\nu_0} = \int_{t_0}^t y(t) dt$$

The Allan standard deviation is defined as the square root of the Allan variance.

13.2.2. Definition of the Noise Processes

The single-sided power spectral density $S_{yy}^+(f)$ of the normalized frequency fluctuations $y(t)$ can be modelled by a polynomial

$$\text{Eq. 17} \quad S_{yy}^+(f) = \sum_{i=-2}^{i=+2} h_i \cdot f^i$$

that defines the different types of noise processes that can be present in an oscillator. Their designation is given in Table 10.

The single-sided power spectral density $S_{yy}^+(f)$ of the normalized frequency fluctuations $y(t)$ can be modelled by a polynomial

Coefficient	Definition
h_{-2}	Random Walk of Frequency
h_{-1}	Flicker of Frequency
h_0	White Frequency
h_1	Flicker of Phase
h_2	White Phase

Table 10: Definition of Noise Processes

The single-sided power spectral density $S_{xx}^+(f)$ of the time error $x(t)$ [s] fluctuations, the single-sided power spectral density $S_{\Phi\Phi}^+(f)$ of the phase noise process $\phi(t)$ fluctuations and the spectral purity L (script L) are given by:

$$\text{Eq. 18} \quad S_{xx}^+(f) = \frac{1}{(2\pi f)^2} S_{yy}^+(f),$$

$$\text{Eq. 19} \quad S_{\Phi\Phi}^+(f) = (2\pi\nu_0)^2 \cdot S_{xx}^+(f) \text{ and}$$

$$\text{Eq. 20} \quad L(f) = \frac{1}{2} S_{\Phi\Phi}^+(f) = \frac{\nu_o^2}{2} \sum_{i=-2}^{i=+2} h_i \cdot f^{i-2}$$



In terms of linear operators, the original process $y(t)$ is filtered by a moving average operator modelling the action of the counter, followed by a first difference operator. The relation between the Allan variation and the single-sided power spectral density $S_{yy}^+(f)$ of the normalized frequency fluctuations $y(t)$ is given by

$$\text{Eq. 21} \quad \sigma_y^2(\tau) = 2 \int_0^{\infty} S_{yy}^+(f) \frac{\sin^4(\pi f \tau)}{(\pi f \tau)^2} df$$

The above integral is defined and finite for all the power-law processes of Table 10.

Table 11 shows the Allan variance and $L(f)$ for the different noise processes. For certain types of noise processes the Allan variance is a function of the system bandwidth f_c and of the sampling interval τ_0 . f_c is defined as the -3 dB cut-off frequency of an equivalent first order low-pass filter that limits the bandwidth of the beat signal fed to the frequency counter. In Table 11, it is assumed that the averaging time τ is large compared to the time constant of the filter.

Noise type	$S_{yy}^+(f)$	$\sigma^2(\tau)$ for $2\pi f_c \tau \gg 1$	$L(f)$
Random Walk of Frequency	$h_{-2} f^{-2}$	$\frac{2}{3} \pi^2 h_{-2} \tau$	$\frac{v_o^2}{2} h_{-2} f^{-4}$
Flicker of Frequency	$h_{-1} f^{-1}$	$2 \ln 2 h_{-1}$	$\frac{v_o^2}{2} h_{-1} f^{-3}$
White Frequency	h_0	$\frac{1}{2} h_0 \tau^{-1}$	$\frac{v_o^2}{2} h_0 f^{-2}$
Flicker of Phase	$h_1 f$	$\frac{1.038 + 3 \ln(2\pi f_c \tau_0)}{4\pi^2} h_1 \tau^{-2}$	$\frac{v_o^2}{2} h_1 f^{-1}$
White Phase	$h_2 f^2$	$\frac{3f_c}{4\pi^2} h_2 \tau^{-2}$	$\frac{v_o^2}{2} h_2 f^0$

Table 11: Allan Variance & $L(f)$ for Different Noise Processes



13.3. Frequency Offset, Frequency Drift & Time Error

In case of a linear frequency drift $\alpha_y [s^{-1}]$, the relative frequency evolution is given by

Eq. 22 $y(t) = y_0 + \alpha_y \cdot t$, where y_0 is the frequency offset

And the time error evolution is given by

Eq. 23 $x(t) = x_0 + y_0 \cdot t + \frac{1}{2} \alpha_y \cdot t^2$, where x_0 is the time error offset

For a frequency drift of $1 \cdot 10^{-14} / day$ corresponding to $\alpha_y = \frac{1 \cdot 10^{-14}}{24 \cdot 3600} = 1.16 \cdot 10^{-19} [s^{-1}]$

and a frequency offset adjusted to $y_0 = 1 \cdot 10^{-14}$, the increase of the time error after 10 days is 52 ns with a 43 ns contribution of the frequency drift and a 9 ns contribution of the frequency offset.

With the same offset and drift conditions, the increase of the time error after 1 year is 57.9 μs with a 57.6 μs contribution of the frequency drift and a 0.3 μs contribution of the frequency offset.

14. CE Certifications (March 2008)



- EN 55022 class B + EN 55024 (Information)
- EN 61326-1 (Equipment for measurement, control and laboratory use)