



**Atacama  
Large  
Millimeter /  
submillimeter  
Array**

## **Interface Control Document Between ALMA Phasing Project And ALMA Back End**

**ALMA-05.11.10.49-0002-A-ICD**

2014-10-07

<b>Prepared By:</b>	<b>Organization Role:</b>	<b>Date and Signature:</b>
R. Lacasse / Bill Shillue	NRAO	
Geoff Crew	Haystack Observatory	
<b>Approved By:</b>	<b>Organization Role:</b>	<b>Date and Signature:</b>
Rich Lacasse	NRAO	
Nick Whyborn	ALMA Array Lead Engineer	
Jorge Castillo	Back End Technical Lead	
<b>Released By:</b>	<b>Organization Role:</b>	<b>Date and Signature:</b>
Michael Hecht	Development Project Manager	



## Change Record

Version	Date	Affected Section(s)	Author	Reason/Initiation/Remarks
A.1	2013-03-25	ALL	None	First Issue
A.2	2013-04-22	ALL	None	Added many details from Bill Shillue
A.3	2013-08-09	ALL	None	Updated document number to new format
A.4	2014-09-24	ALL	R. Lacasse	Corrected TBD placeholders
A.5	2014-10-03	ALL	R. Lacasse	Corrected additional TBD placeholders and clarified mating connectors in 3.2.1.1
A	2014-10-08	Figure 3	R. Lacasse	Updated figure 3.

### Table of Contents

1	Description .....	4
1.1	Purpose .....	4
1.2	Scope .....	4
2	Applicable Document, Reference Documents, Acronyms and Definitions .....	5
2.1	Applicable Documents .....	5
2.2	Reference Documents .....	5
2.3	Abbreviations and Acronyms .....	6
3	Interfaces to Various Subsystems .....	6
3.1	Hydrogen Maser .....	6
3.1.1	Introduction .....	6
3.1.2	Background .....	6
3.1.3	Test and Verification .....	10
3.2	64-Antenna Correlator Upgrades .....	11
3.2.1	Interfaces to Back End .....	11



## List of Figures

Figure 1: ALMA CLOA (shaded red box), with interface to Correlator and Antennas indicated, before ALMA Phasing Project elements are added .....	7
Figure 2: ALMA CLOA (shaded red box), with interface to Correlator and Antennas indicated, with ALMA Phasing Project elements added .....	7
Figure 3: Interconnect diagram .....	8
Figure 4: 10 MHz RF cabling and power level to CVR, in existing CLOA.....	10
Figure 5: 10MHz RF cabling and power level to CVR, proposed change of ALMA Phasing.....	10



# 1 Description

## 1.1 Purpose

This ICD covers the all interfaces between ALMA Back End and the ALMA Phasing Project (APP).

## 1.2 Scope

The ALMA Phasing Project provides ALMA with the capability of phasing up to 63 Antennas and recording the resulting data for later correlation at another facility (e.g., Haystack Observatory). Equipment associated with the project includes a hydrogen maser for VLBI phase stability, various upgrades to the 64-Antenna Correlator, an optical data transmission system to transmit data over a single fiber from the AOS to OSF and a data recording system. This equipment is more fully described in reference documents [AD01]. Some of these subsystems may have several interfaces to the ALMA Observatory (e.g. hardware and software). This document covers only the interfaces with Back End.

The ALMA Phasing Project is identified in the following document [AD01].

The ALMA Central LO Article design is defined in [AD02] and its performance requirements are detailed in [AD03]. A summary of interface requirements between the ALMA CLOA and the ALMA AOS Technical Building in which it resides is included in [AD04].

The ALMA Environmental requirements, which includes environmental requirements and conditions presented in the AOS Technical Building and at the OSF site, is contained in [AD05]. Seismic specifications are detailed in [AD06].



## 2 Applicable Document, Reference Documents, Acronyms and Definitions

Applicable documents are necessary for the understanding of this document. In some cases, they provide additional requirements which are to be incorporated into the ICD. Reference documents are supplemental and simply provide further reference for various topics. In most cases, the acronyms used in this document are consistent with ALMA defined acronyms, however additional acronyms have also been listed which are outside the scope of ALMA definitions. No distinction is made between these two uses.

### 2.1 Applicable Documents

The following documents, of the exact issue shown, form part of this document. In the event of conflict between the documents listed here and this document, this document shall take precedence.

Ref.	Document Title	Reference
[AD01]	APP Project Plan <i>Release 1.1 11-Oct-12</i>	ALMA Phasing Project, Project Plan 1.1, 11-Oct-12
[AD02]	BE IPT CLOA Design Description	<a href="#">BEND-50.01.00.00-012-A-DSN</a>
[AD03]	Central LO Article Verification and Acceptance Plan	<a href="#">BEND-50.01.00.00-002-A-PLA</a>
[AD04]	ICD between AOS Technical Bldg and BE Central Equipment	<a href="#">ALMA-20.01.02.00-50.00.00.00-A-ICD</a>
[AD05]	ALMA Environmental Specification	<a href="#">ALMA-80.05.02.00-001-B-SPE</a>
[AD06]	Seismic Design Specifications for ALMA-AOS and ALMA-OSF	<a href="#">SYSE-80.10.00.00-002-B-REP</a>
[AD07]	General Safety Design Specification	<a href="#">ALMA-10.08.00.00-003-B-SPE</a>
[AD08]	Product Assurance Requirements	<a href="#">ALMA-80.11.00.00-001-B-GEN</a>

### 2.2 Reference Documents

Ref.	Document Title	Reference
[RD01]	AOS Technical Building Completion Package Construction Specifications	<a href="#">SITE-20.01.02.03-027-A-SPE</a>
[RD02]	ALMA Project Backend IPT Seismic Support Specification	<a href="#">BEND-57.00.00.00-001-A-SPE</a>
[RD03]	ALMA Project Backend IPT Addendum to Seismic Support Specification	<a href="#">BEND-57.00.00.00-003-A-SPE</a>
[RD04]	ALMA Back End IPT Central LO Seismic Rack SPECIFICATION	<a href="#">BEND-57.02.03.00-002-A-SPE</a>
[RD05]	Central LO Rack Production Drawings	<a href="#">BEND-57.02.03.00-006-A-DWG</a>
[RD06]	Operation and Maintenance Manual for CLOA Equip. Racks	<a href="#">BEND-57.02.03.00-005-A-MAN</a>
[RD07]	iMaser™ 3000, Installation, Operation & Maintenance User Manual, Issue 1.7, 28-May-2010	T4S-MAN-0012, available from <a href="http://www.T4Science.com">www.T4Science.com</a>
[RD08]	iMaser™ 3000 Specifications	<a href="http://www.t4science.com/documents/iMaser_Clock_Spec.pdf">http://www.t4science.com/documents/iMaser_Clock_Spec.pdf</a>
[RD09]	Test Report for T4S iMaser s/n 59	T4 Science SA, Doc. No. Test Report 0029
[RD10]	64 Antenna Correlator Specifications and Requirements	<a href="#">ALMA-60.00.00.00-001-C-SPE</a>
[RD11]	Interface Control Document Between: Back End And: 64-Antenna Correlator	<a href="#">ALMA-50.00.00.00-60.00.00.00-B-SPE</a>
[RD12]	ALMA Back End Central Reference Generator Stability Test for ALMA Phasing Project	<a href="#">BEND-55.03.00.00-0026-A-TDR</a>
[RD13]	Interface Control Document Between ALMA Phasing Project And ALMA Correlator	ALMA-05.11.10.49-60.00.00.49-A-ICD



## 2.3 Abbreviations and Acronyms

All acronyms and abbreviations used within this document are given at the [ALMA Acronym Finder](#) web page.

## 3 Interfaces to Various Subsystems

This section includes the detailed interfaces to the various subsystems comprising the ALMA Phasing System. A section is dedicated to each subsystem.

### 3.1 Hydrogen Maser

#### 3.1.1 Introduction

VLBI observations require extremely good phase stability because the phase stability between geographically separated telescopes is required (Allan deviation of  $2 \times 10^{-15}$  at 1000 seconds). This is a contrast with connected interferometers, like ALMA, where frequency references for all antennas are derived from a single reference. The frequency reference provided with the original ALMA array, while adequate for connected-element interferometry, is not adequate for VLBI at millimeter wavelengths. Thus a hydrogen maser is provided as a deliverable of the Phasing Project.

In particular, the hydrogen maser provided is:

**Manufacturer:** T4 Science SA

**Model Number:** iMaser 3000

The interfaces of this subsystem to Back End are detailed in this section.

#### 3.1.2 Background

The ALMA Central Local Oscillator was installed in 2009, and expanded in 2011. It has been in use since that time for ALMA Early Science. The ALMA Phasing Project (APP) is an external international development effort that will enable ALMA to participate in ultra-high resolution VLBI and high frequency phased array science [AD01].

The following block diagram illustrates the interface that is the subject of this document. This diagram is consistent with Figure 2.1 of [AD01] but adds detail to the CLOA elements: H-Maser, GPS, CRD, CRG, CVR, ...etc.

In the first figure, the ALMA CLOA is shown before the addition of elements required for the ALMA Phasing Project.

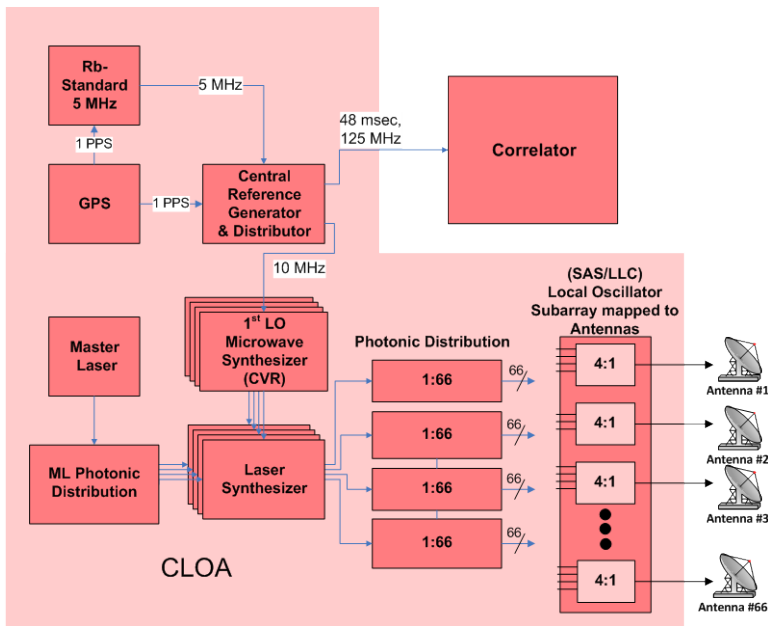

Figure 1: ALMA CLOA (shaded red box), with interface to Correlator and Antennas indicated, before ALMA Phasing Project elements are added

The changes necessary to accommodate the ALMA Phasing Project are shown next.

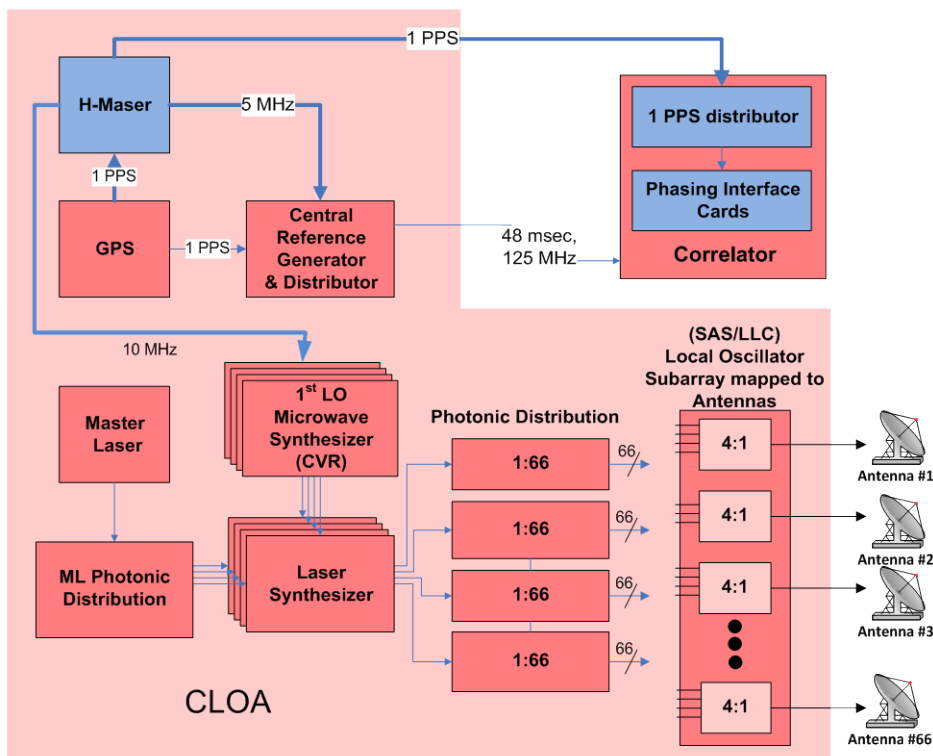

Figure 2: ALMA CLOA (shaded red box), with interface to Correlator and Antennas indicated, with ALMA Phasing Project elements added

The added elements and the section number of this document where the interface requirement is discussed are included in **Table 1**.



N	Interface Change Description	Section #
1	Hydrogen Maser (H-Maser)	3.1
2	Cabling	3.1.2.1.2
3	Change of 5 MHz now coming from the H-Maser to the MFS	3.1.2.1.3
4	Change of 10 MHz now coming from the H-Maser to the CVRs	3.1.2.1.4

**Table 1: Interface description and index**

### 3.1.2.1 Electronic and Signal Interfaces

#### 3.1.2.1.1 Interconnection Diagram

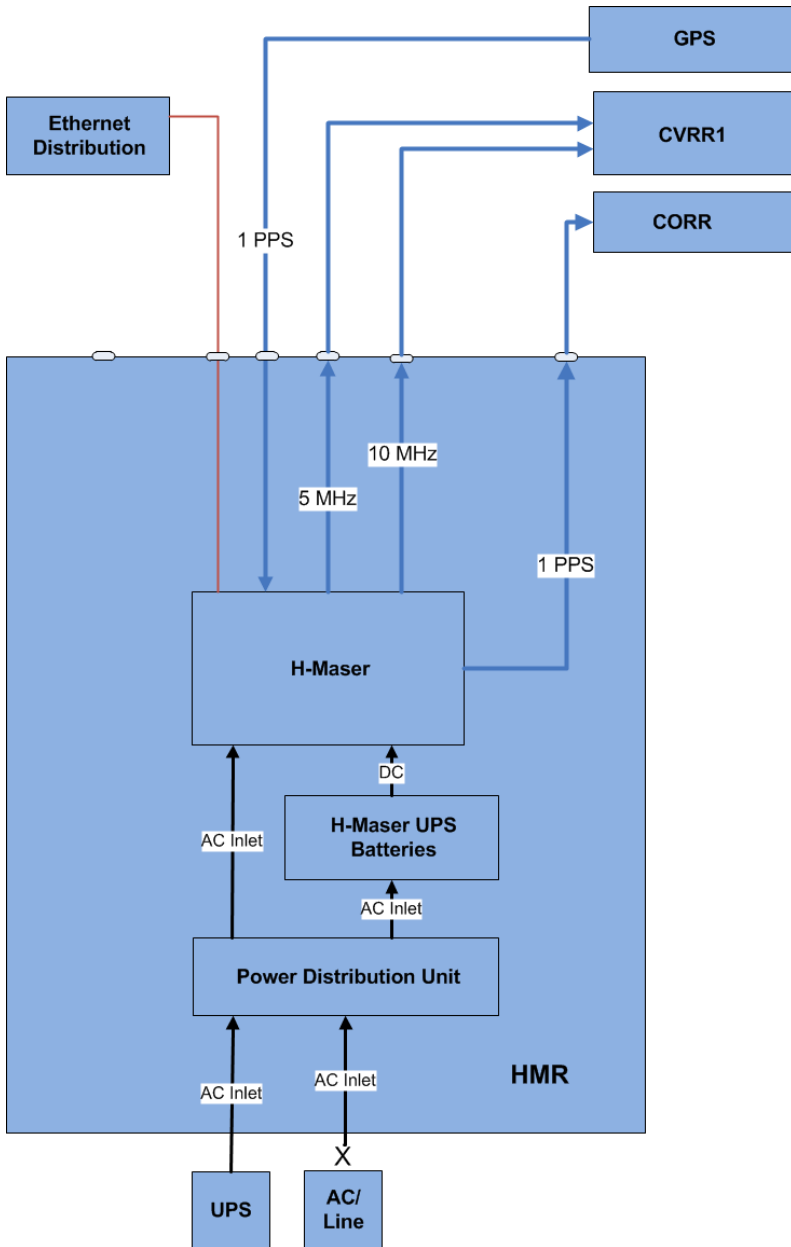

**Figure 3: Interconnect diagram**

#### 3.1.2.1.2 Cabling

Overhead cable trays for supporting fiber optic, RF and other signal cables are installed between the Patch Panel room, the LO room, the Correlator room, and the Computer Equipment room. In the equipment rooms, the trays are below the ceiling but above the racks. There are framed access





holes in the wall(s) between rooms for passage of the cable trays [AD04]. All cabling between the HMR and Correlator, HMR and CVRR1, and HMR and GPS, shall utilize the overhead cable trays.

### 3.1.2.1.3 5 MHz output

The 5 MHz maser output provides the exceptional hydrogen maser stability to the Central Reference Generator (CRG). As shown in **Error! Reference source not found.**, a cable is needed between the H-maser and the HMR top panel, and a second cable between the HMR top panel and the CVRR1 rack top panel, for this 5 MHz connection.

HMR top panel connector interface: N-Type, female

5 MHz cable internal to HMR

Cable type: COAX

Connector type: SMA

Length of cable: min. 1 m

5 MHz cable between HMR and CVRR1 rack

Cable type: RG213 COAX

Connector type: N-Type, male

Length of cable: min. 6.0 m

Patch Panel room, the LO room, the Correlator room, and the Computer

Power level: The power level *at the input to the CRG* must be in the range of 10-15 dBm.

### 3.1.2.1.4 10 MHz output

The maser also has a 10 MHz output that will be used to provide a phase stable reference to the ALMA Central Variable Reference Microwave synthesizers. The 10 MHz is derived internally from the maser by a low phase drift doubler and buffer stage. This has been shown to provide superior stability as compared to the CRG 10 MHz output [RD12].

### 3.1.2.1.5 10 MHz cabling change internal to CVRR1 rack

The ALMA CVRR1 and CVRR2 racks need to be recabled so that the CVR can take 10 MHz reference from the maser instead of the CRG. The current ALMA CLOA configuration is shown in Figure 4. The CRG 10 MHz output is 14 dBm, and is split six ways in a cascade of 1:2 split and 1:3 splitters, as shown. The resulting power at the CVR input is 3.7 dBm. The proposed new arrangement is shown in Figure 5. The 10 MHz can be brought into the CVRR1 rack by an existing spare bulkhead N connector. Then the 10 MHz from the maser is brought to the six-way split input. The maser output power level at 10 MHz is nominally 13 dBm. So the power level at the CVR will be lower by approximately 1 dB. However, the CXVR input reference power level is 5 dBm +/- 5 dB, so the power levels will be well within limits with this arrangement.

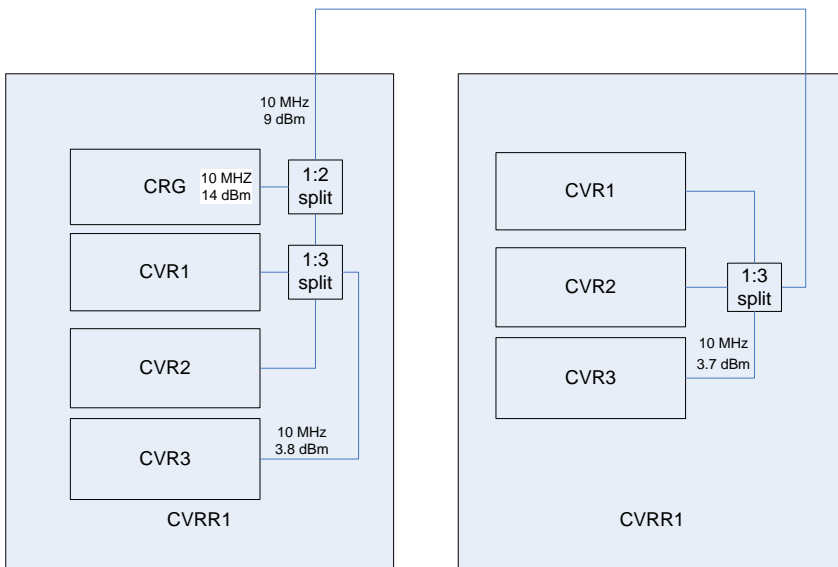

Figure 4: 10 MHz RF cabling and power level to CVR, in existing CLOA

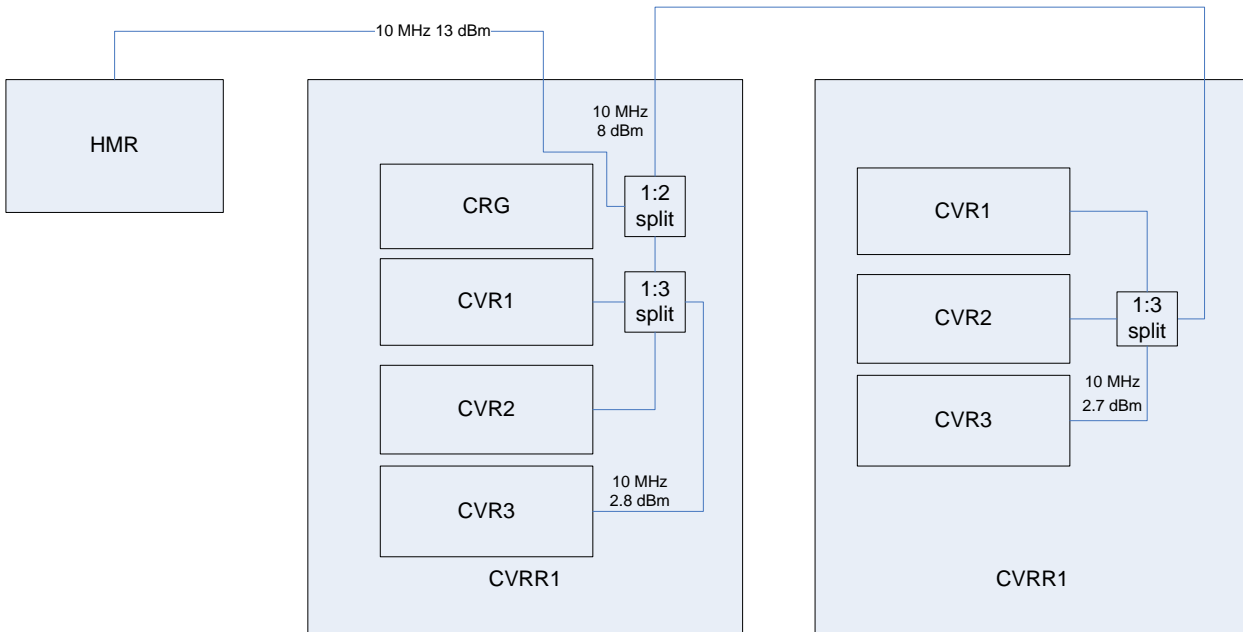

Figure 5: 10MHz RF cabling and power level to CVR, proposed change of ALMA Phasing

Also note that the CVR reference 10 MHz input has an adjustable loop bandwidth that can be set to 25 MHz, 55 MHz, 125 MHz, 300 MHz, or 650 MHz.

A total of three new cables are needed to carry the 10 MHz from the maser to the CVRR1 1:2 splitter. These are for the segments within the HMR, within the CVRR1, and between the two racks.

### 3.1.3 Test and Verification

After the installation of the H-maser, HMR rack, and assemblies; and after the installation of the cabling required to interface these to the ALMA CLOA, test and verification must be performed. These shall consist of:



- Test and verification of the H-Maser correct operation
- Test and verification of the H-Maser monitor and control interface
- Test and verification of the 1 PPS and 5 MHz, 10 MHz output signals
- Test and verification of the CLOA correct operation

The full suite of tests and procedures shall be documented and approved prior to the installation.

## **3.2 64-Antenna Correlator Upgrades**

The specification for the 64-Antenna Correlator [RD10] includes a requirement that the correlator provide “hooks” for VLBI. To take advantage of these hooks, various modifications to the correlator are required. Hardware modifications to the correlator are documented separately in [RD13]. This section details the interface between ALMA Phasing Equipment housed in the 64-Antenna Correlator and ALMA Back End.

### **3.2.1 Interfaces to Back End**

#### **3.2.1.1 1-PPS distributor**

A 1-PPS distributor is required to distribute two types of 1-PPS signals to each PIC. (The PICs are new boards which will be installed in the correlator and are described in [AD01].) The 1-PPS signals originate from the 1-PPS distributor in the CLO room and from a local GPS receiver located in the correlator room. In addition, the 1-PPS distributor shall receive 1-PPS signals from the 8 PICs and make them available on connectors for monitoring. This section describes the details of the interface with the 1-PPS signal from Back End, in the CLO room.

The 1-PPS signal provided to the 1-PPS distributor in the Correlator room from the Back End must be derived the Maser 1-PPS. The interface is very similar to the TE interface described in [RD11]. The requirements of the interface include the following:

- The 1-PPS rising edge designates the 1-PPS event.
- Transmission standard: TTL terminated(0 to 2.5 V into 50 ohms)
- Cable type: RG-213COAX,
  - selected to deliver a rising time of 10 ns or better at the Correlator end
  - to be provided by the APP
  - BNC male at both ends
- Mating Connector at Back End: N-type, male (ALMA to supply BNC to N-type adapter)
- Mating Connector at Correlator End: BNC, 50 ohm