

# DBBC3

## A Full Digital Implementation of the VLBI2010 Backend

G. Tuccari

# DBBC3

- Project supported by EU Radionet3
- Partner:
  - INAF – Italy
  - MPIfR - Germany
  - OSO – Sweden
- Formally starting date July 2012, 3 years

# Background

- Astronomic VLBI requires improvement in the overall sensitivity (4Gbps EVN, mmVLBI)
- Geodetic VLBI requires improvement in delay determination (VLBI2010)
- Current state of the art technologies offer new opportunity
- Two generation of the DBBC system represent a good platform

# DBBC Evolution

- DBBC1**      2004 - 2008  
in: 4 x IF-512MHz  
out: **DDC** 16xbbc(1-2-4-8-16MHz)@32MHz  
**0.512/1.024Gbps**
- DBBC2**      2007 – to date  
in: 4 x IF-512/1024MHz  
out: **DDC** 16xbbc(1-2-4-8-16MHz)@32MHz  
**PFB** 4 x 16 x 32MHz@64MHz  
**4.096/8.192Gbps**
- DBBC2010**    2009 – to date  
in: 8 x IF – 512/1024MHz  
out: **PFB / DSC**      **16.384/32.768Gbps**

# DBBC3 General Performance

- Number of Input IF: **4**
- Instantaneous bandwidth each RF: **14 GHz**
- Sampling representation: **8 bit**
- Processing capability: **max 10 TMACS**  
(multiplication-accumulation per second)
- Output: **max 1.4 Tbps (64b/66b encoded)**
- Compatibility with existing DBBC environment

# DBBC3 General Architecture

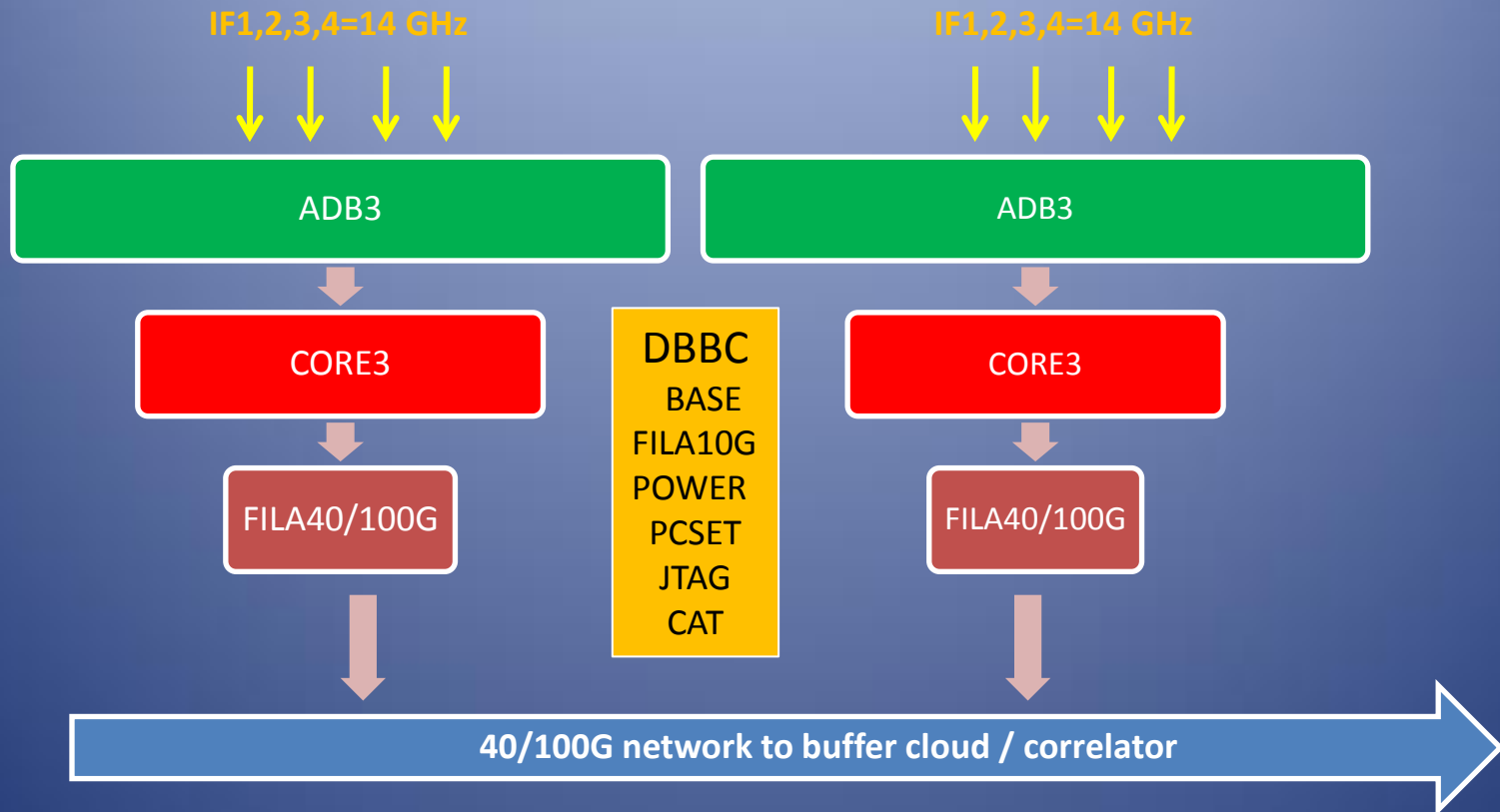

# Full Band Digital Direct Conversion (each RF band)

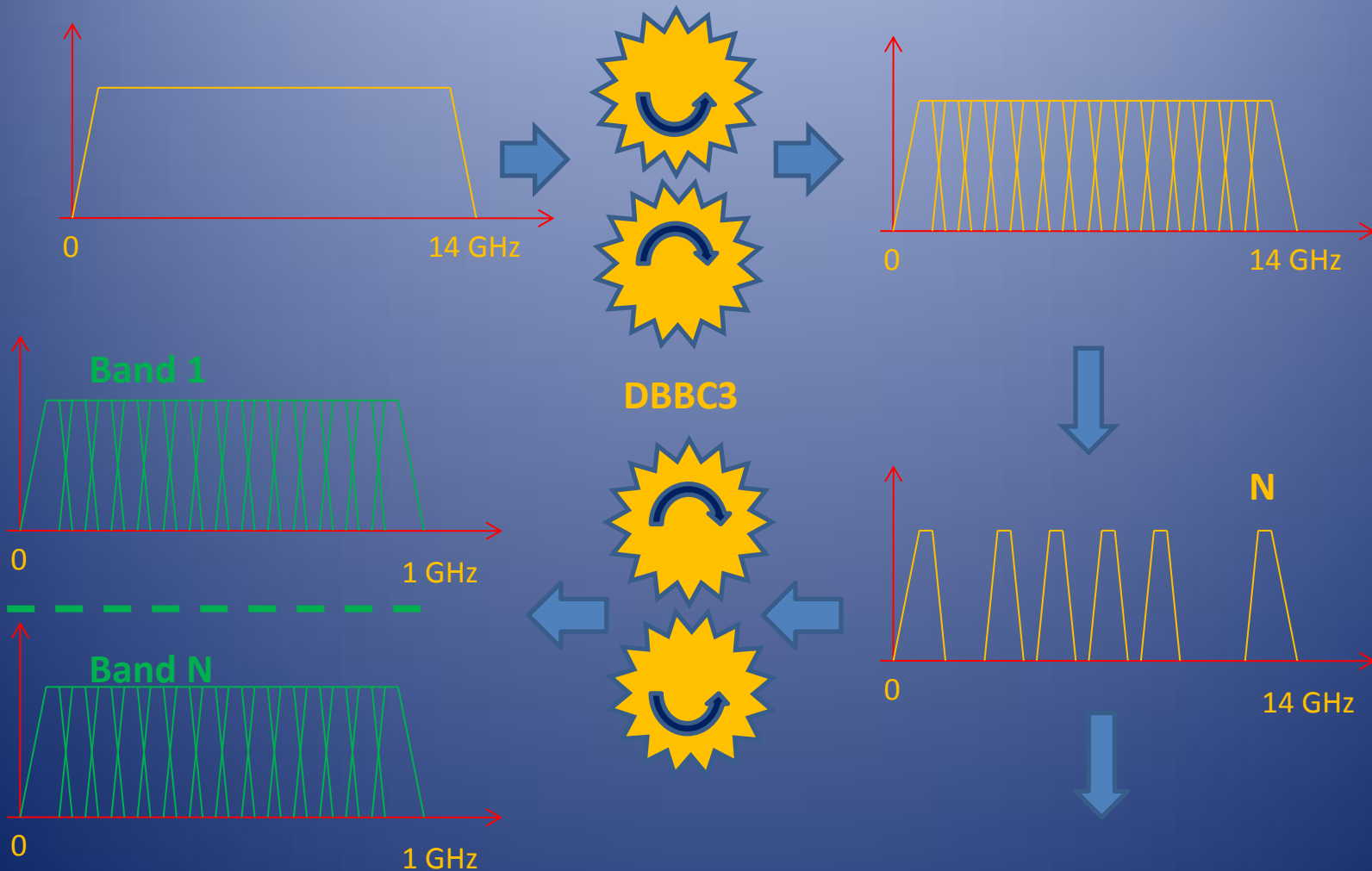

# DBBC3 Architecture to support VLBI2010

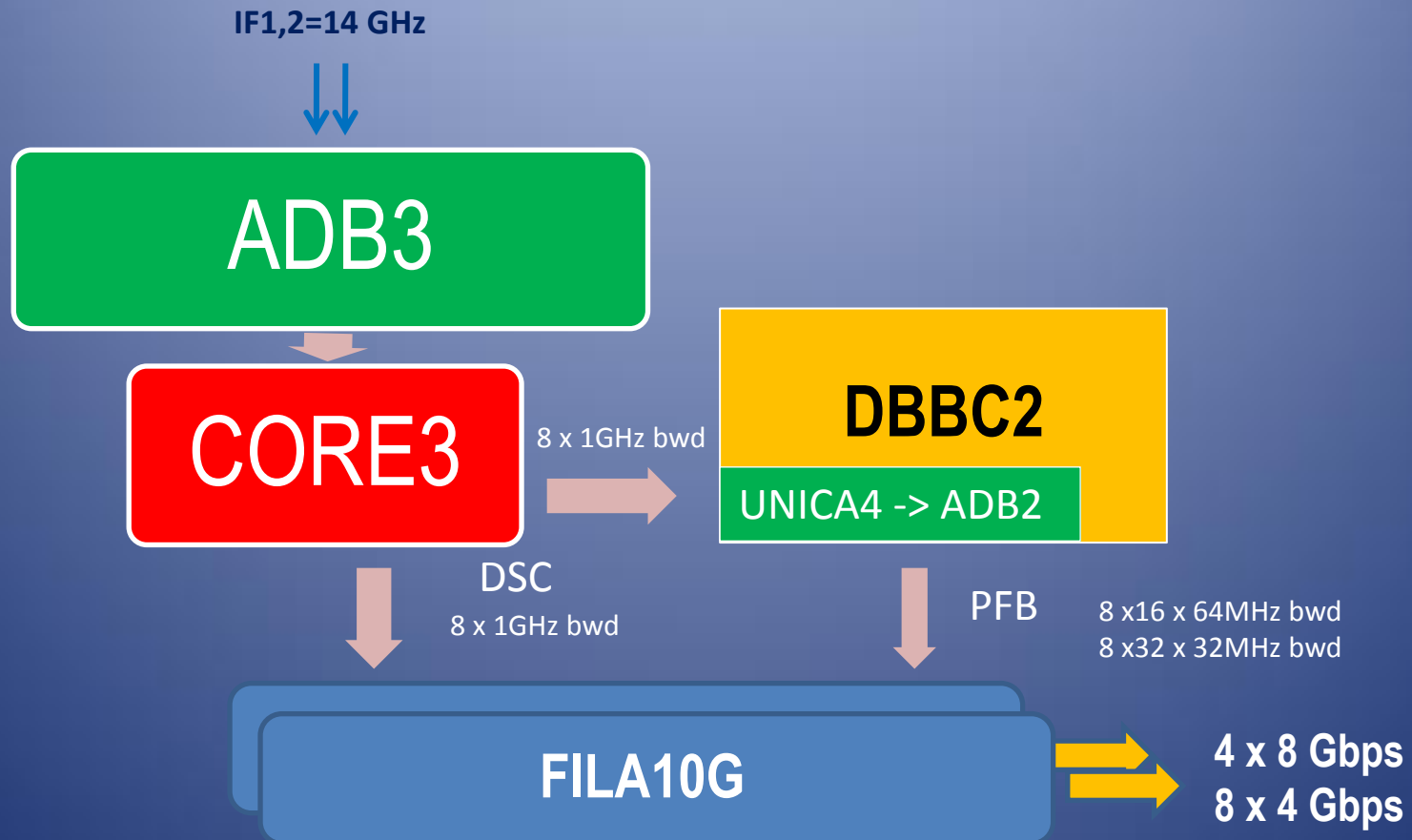



# VLBI2010 Conversion Chain (each polarization)

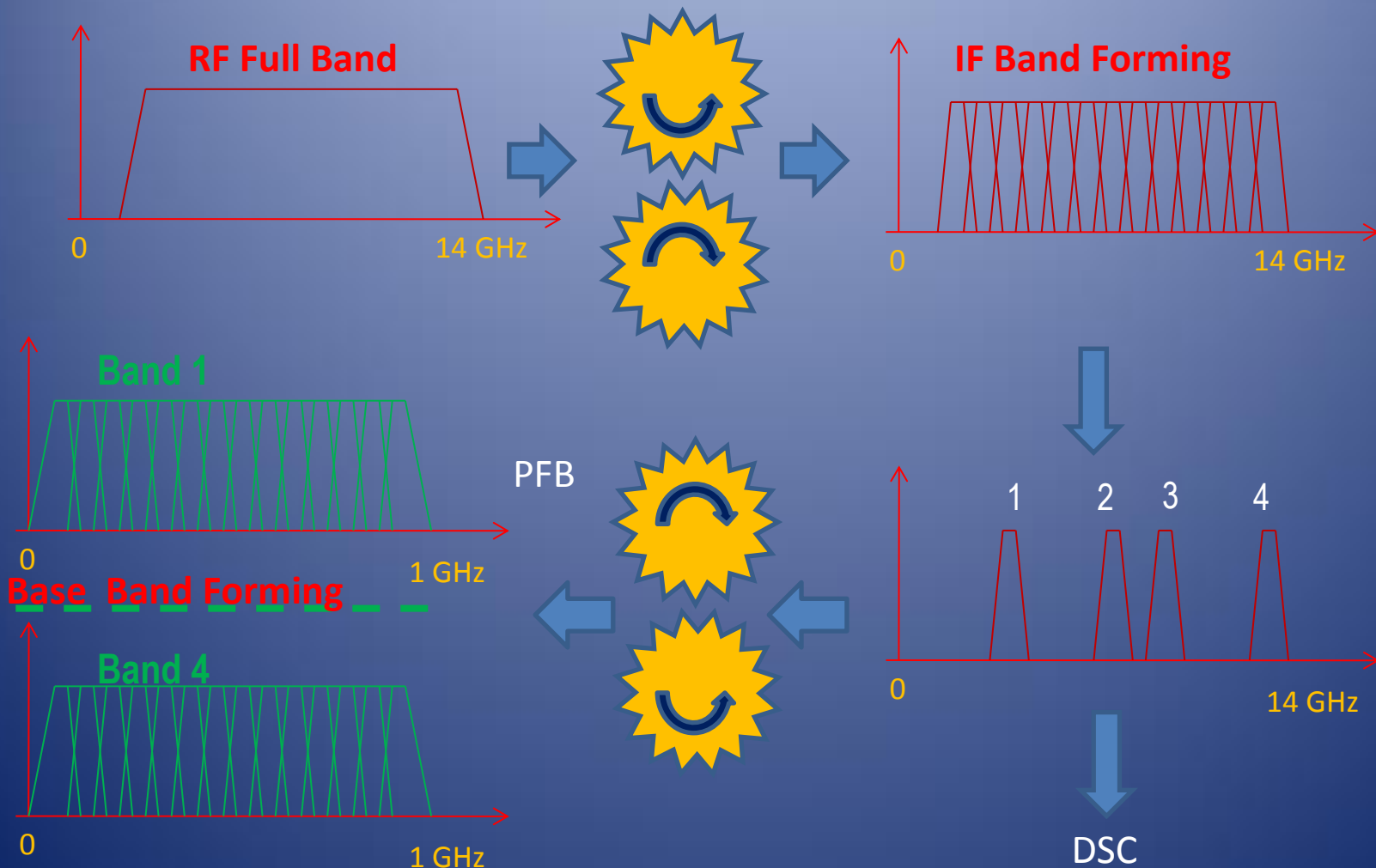

# ADB3 Sampler

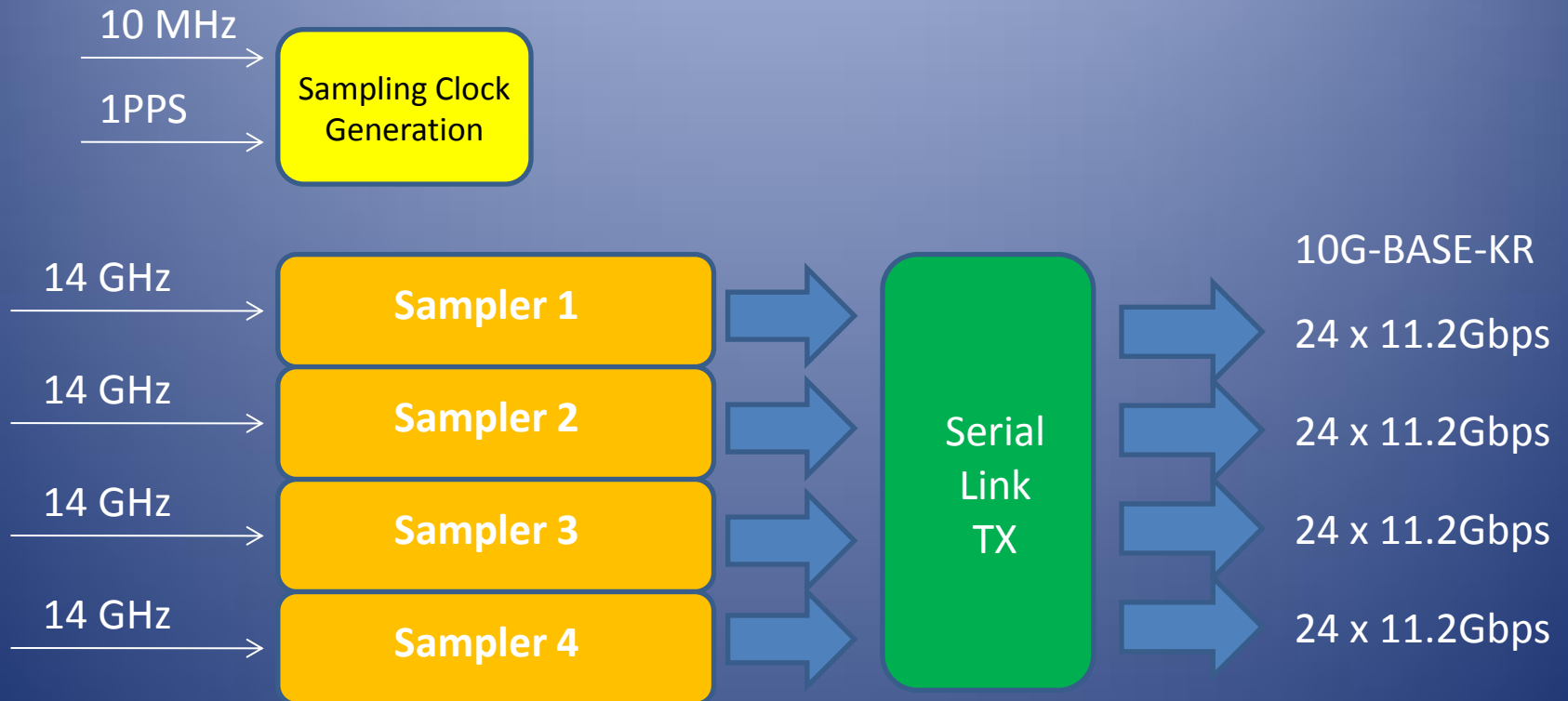

# CORE3

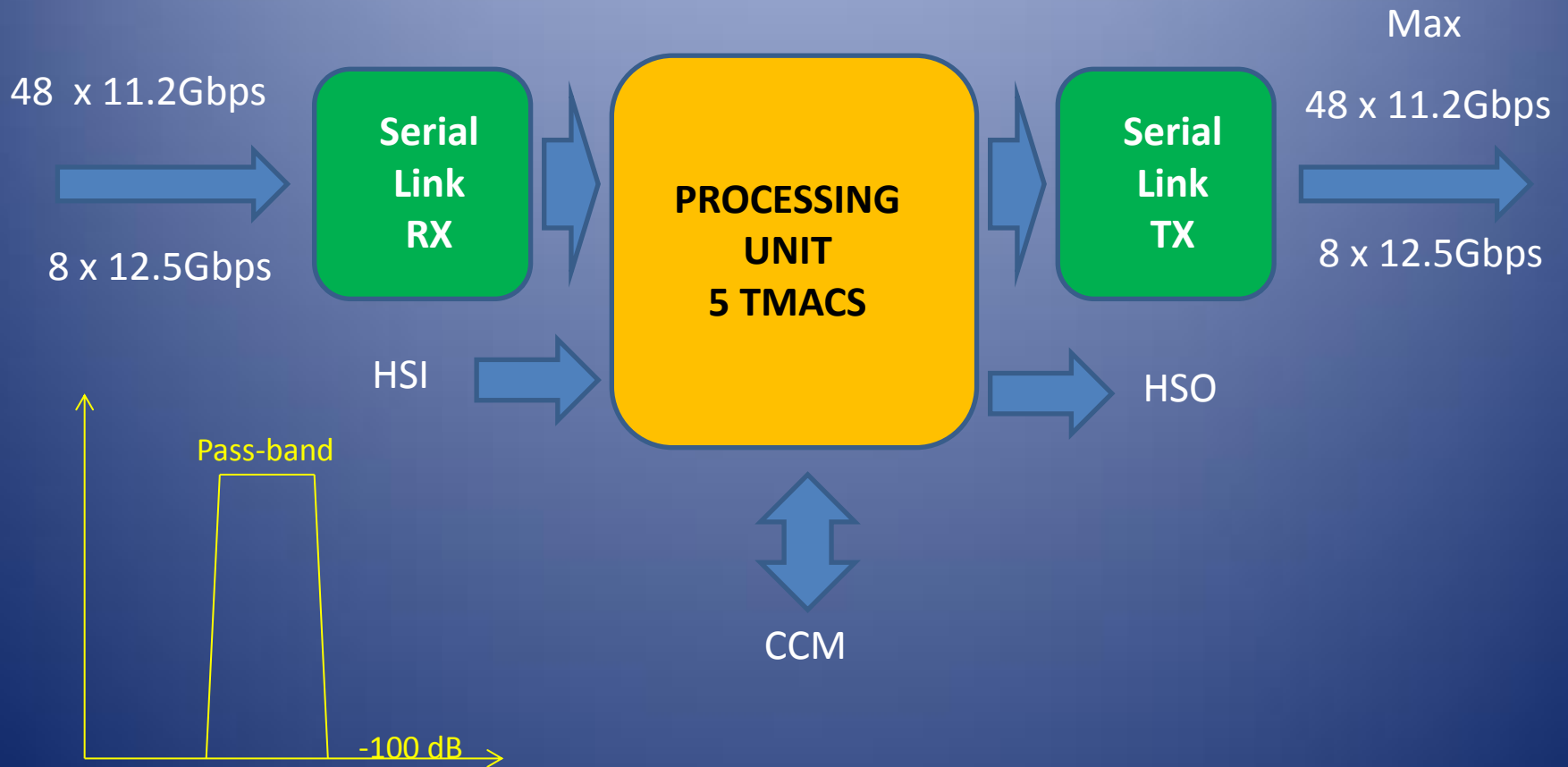

# FILA40/100G

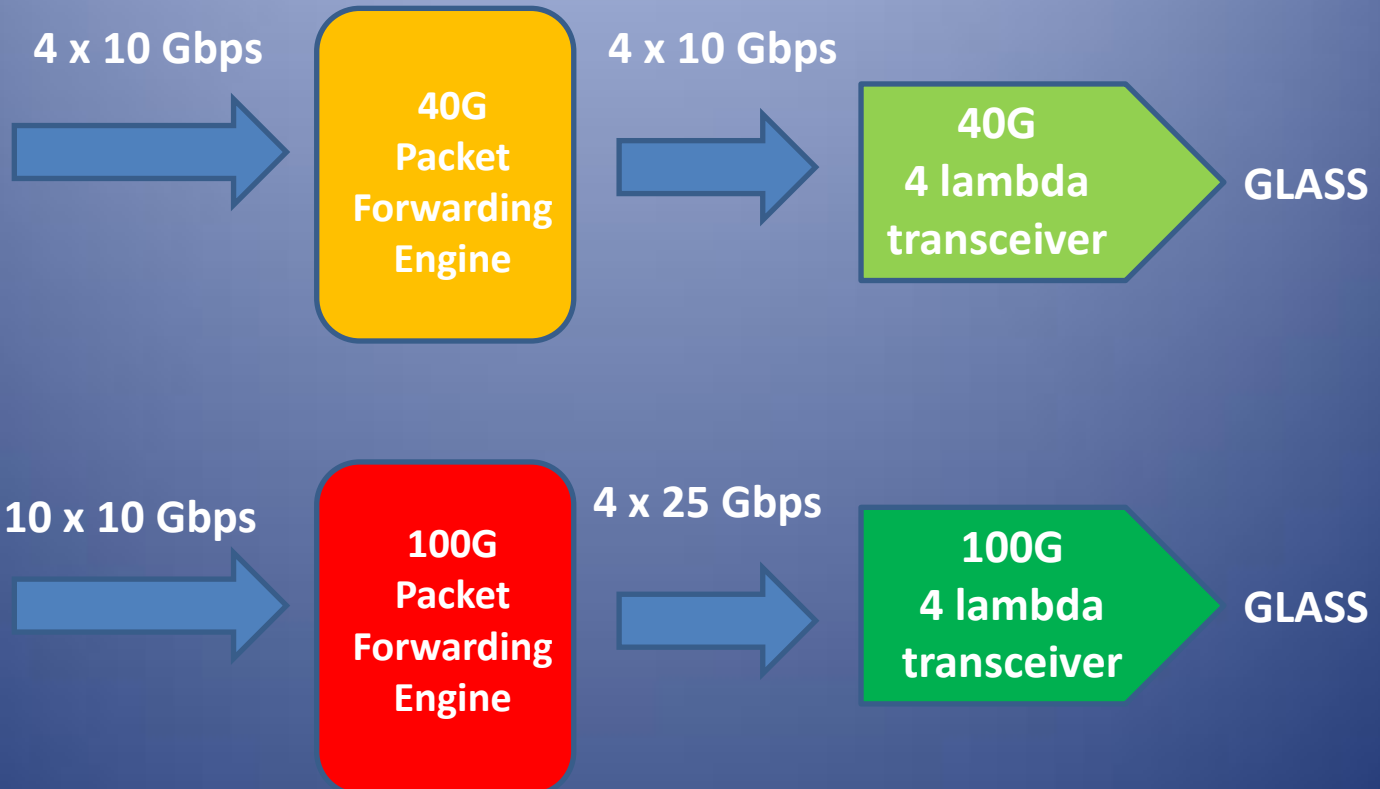

# Status and planning

- ADB3 project underway: second series with two prototypes available
- Measurements in lab showed good performance in cross-correlation amplitude and phase
- Test in antenna as soon as available 2-14 GHz feeds
- Core3 firmware for VLBI2010: 4 IF forming under development, tunable 100dB class pass-band filters
- The project **must** produce deliverables in 3 years

# ADB3 – Prototype second series

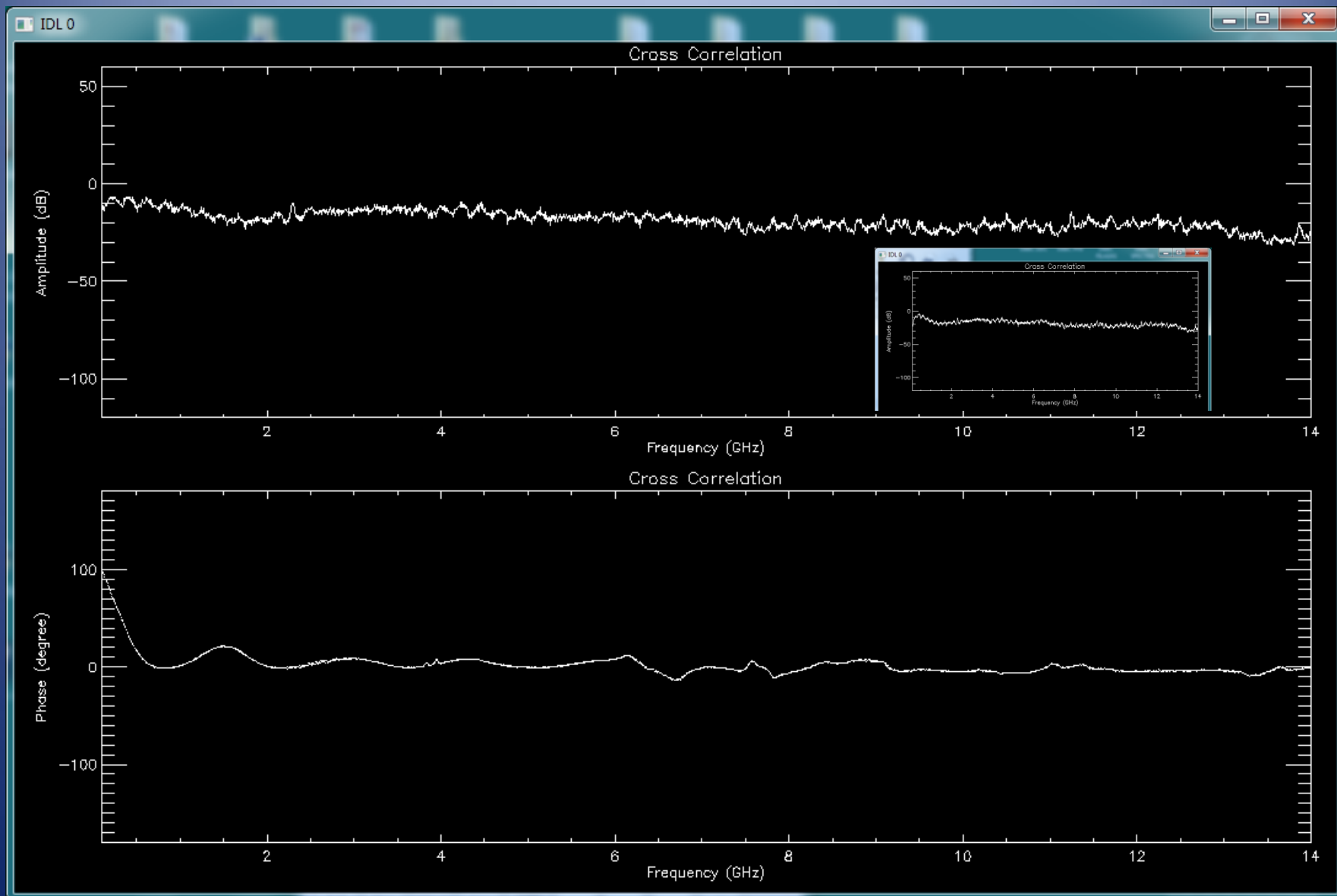

THANK YOU – Questions?